



Quantitative Consequence Assessment of Industrial Accidents Supported by Dynamic Process Simulators

Gabriele Landucci^{a,b,*}, Alessio Pupillo^a, Alessio Mencaroni^a, Gabriele Pannocchia^a

^aDipartimento di Ingegneria Civile ed Industriale, Università di Pisa, Largo Lucio Lazzarino 1, 56122, Pisa, Italia.

^bInstitute of Security and Global Affairs, Faculty of Governance and Global Affairs, Leiden University, Wijnhaven, Turfmarkt 99, 2511 DP, Den Haag (the Netherlands)

gabriele.landucci@unipi.it; g.landucci@fpga.leidenuniv.nl

In the present work, process simulators are adopted in the framework of consequence assessment support. A novel methodology is developed, with particular reference to consequence assessment specific for O&G offshore sector. A commercial, high-fidelity process simulator, Honeywell UniSim® Design R460, is applied for the analysis of accidental scenarios in order to perform a detailed evaluation of dynamic response of a given process unit and to support the consequence assessment of industrial accidents. A specific set-up of process simulator is developed to reproduce either source term, e.g. estimation of gas or liquid flow rate from process leaks, and physical effects dynamics. In particular, the physical effects evaluation through integral models of hydrocarbon fires is integrated in the dynamic process simulator, possibly accounting for the presence of safety barriers. Specific features of simulators are exploited to evaluate the consequences of possible failures in actuators and safety barriers. Some case studies of industrial interest are discussed to demonstrate the application of the methodology.

1. Introduction

Prevention of major accidents in the Oil and Gas (O&G) industry claims for both continuous learning from events occurring around us and tireless surveillance of critical safety systems. At the same time, more advanced safety assessment tools are needed to provide accurate and real-time response of process systems and to ensure emergency and preparedness in the operators' response (HSE, 2006).

In the O&G sector, Quantitative Risk Analysis (QRA) is a consolidated tool to support the safe design of process installations. A critical step of QRA is the consequence assessment, aimed at estimating the magnitude contribution to the risk using engineering and mathematical techniques (Lees, 1996). Magnitude is related to both vulnerability of territory and severity of scenarios. Hence it is often considered as a static term associated with the potential hazard in conventional QRA frameworks and often carried out with simplifications (AIChE-CCPS, 2000). This is due to the high number of scenarios considered in a typical QRA study (Uijt de Haag and Ale, 1999) and the uncertainties affecting the release schematization and physical effects modelling (Van Den Bosh and Weterings, 1997). These issues induce overly conservative predictions, neglecting accident transient features and also without the possibility to assess the response of safety barriers (Landucci et al., 2016).

Process simulators are nowadays consolidated tools for the analysis of industrial processes, e.g. in the chemical, petrochemical and O&G industries. Those tools are often used to design or analyse a process in steady state conditions. In particular, they are useful support for the quantification of heat and material balances, taking into account advanced thermodynamic modelling for multicomponent and multiphase systems and the features of the most common types of equipment. Process simulators may be also used in dynamic mode, performing the detailed analysis in transient conditions (e.g., analysis of the system response to a given control action or implementing interlocks or different control logics, etc.) but their application in safety studies is not yet consolidated.

Shariff et al. (2006) adopted process simulation in order to support the consequence assessment of vapor cloud explosions, showing the variation of the overall risk level based on the changes in process conditions. Manca and Brambilla (2009) developed a dynamic process and accident simulator in order to support the advanced training of plants operators, allowing for the dynamic characterization of industrial accidents (Brambilla and Manca, 2011) or for the reproduction of case histories, such as the BP Texas City refinery accident (Manca and Brambilla, 2012).

In a previous work, the authors provided an example on the use of dynamic process simulators to support safety analyses (Pannocchia and Landucci, 2014). In particular, a commercial process simulator, Honeywell UniSim® Design R460 (UniSim® in the following), was applied for the analysis of accidental scenarios in order to perform a detailed evaluation of dynamic response of process units. However, the implementation of specific assessment of dynamic evolution of physical effects associated with accidents (e.g., effects of fires, explosions, dispersion) was not implemented so far, and is a crucial aspect to be investigated.

In the present work, a specific methodology is developed in order to implement the analysis of physical effects associated with accidental scenarios through dynamic process simulator. The framework developed by (Pannocchia and Landucci, 2014) is here extended in order to incorporate the consequence assessment of hazardous material release and, at the same time, the evaluation of safety barriers response. The approach is applied to some case studies, featuring a three-phase separator involved in accidental situations, in order to provide an exemplification and to test the potentialities of the present approach.

2. Methodology

2.1 Overview and analysis of safety barriers

In this work we exploit a number of specific features of the dynamic process simulator UniSim® (Honeywell, 2017a) to obtain accurate predictions of accident dynamics. The aim is to obtain quantitative information about the effectiveness of safety barriers and, at the same time, to provide a sound support for the analysis of accident dynamic evolution.

Different types of safety barriers are effective in preventing or mitigating the effects of accident scenarios. According to (AIChE-CCPS, 2001), safety barriers may be classified in three categories: i) passive protection systems, ii) active protection systems and iii) procedural and emergency measures. The present work focuses on the response of the active protection systems, which are typically composed of three subsystems in chain (AIChE-CCPS, 2001): a fire and gas detection system, a treatment system (logic solver, releasing panel or alarm advising operator) and an actuation system (mechanical, instrumented, human etc.) that provides the response action to protect the system. The detection system has the primary function of alerting personnel of the existence of a potential extended fire condition, allowing rapid identification of the location of the fire. The detection system activates emergency alarms, and usually triggers the emergency shutdown system, which is aimed at isolating process units, reducing the potential loss and consequent damage connected to the large inventory release.

2.2 Set-up of process simulator

In dynamic simulations (Honeywell, 2017b), the process simulator UniSim® exploits the actual dimensions of each piece of equipment to take into account rigorously the relation between pressure and flow rate, as well as the associated thermal effects that occur (e.g., the Joule-Thompson effect in valves). Moreover, in dynamic mode it is possible replicate the control logics and algorithms very accurately, e.g. by specifying the valve characteristics, controller tuning, as well as possible malfunctions such as valve friction, losses in instrumental air pressure, etc. It is also possible to define suitable triggers for specific events, and this is particularly useful for studying accidental situations that activate the closure of shutdown valves.

The mentioned features, are adopted in the present work to support the simulation of industrial accidents associated with the release of hazardous materials. In particular, the response of equipment to process deviations (such as pressure build up) is assessed by introducing the response of the control system. At the same time, the process simulator allows i) quantifying the source term of hazardous material release and ii) evaluating the physical effects associated with accidental scenarios. In particular, for demonstration purposes, the simulation of heat radiation from jet fires is shown in this work.

In order to simulate the physical effects associated with the jet fire scenario, a specific template was developed in UniSim® (Honeywell, 2017b). The template, which consists of calculation spreadsheets embedded in the process simulator, implements an adapted version of the Chamberlain model, see (Van Den Bosh and Weterings, 1997) for more details. This model, belonging to the category of the surface emitter models, assumes that heat is radiated from the surface of a solid object (the frustum of a cone in this case) modelling the flame. Firstly, the template estimates the release flowrate based on outflow models for source term evaluation (Van Den Bosh and Weterings, 1997). Next, given the source term, the template calculates

the features of the flame and finally provides an estimation of damage distances, following a threshold-based approach. Damage thresholds adopted in the present work are reported in Table 1.

The template is directly implemented in the UniSim® process flow diagram (PFD) as discussed in Section 3.

Table 1: Threshold values adopted for the estimation of damage distances based on Italian legislation for land use planning (Italian Ministry of Public Works, 2001).

Heat radiation (kW/m ²)	Description of the effect
3	Reversible damages
5	Irreversible effects
7	Incipient lethality
12.5	High lethality and possible domino effect

In order to validate the results obtained with the present approach, the consequence assessment was also carried out through DNV GL Phast™ 8.1 (PHAST in the following), a commercial software package that adopts the same model for jet fire radiation simulation implemented in the process simulator (i.e., the Chamberlain model (Van Den Bosh and Weterings, 1997)). PHAST is currently one of the most frequently applied software packages used in QRA studies and was extensively validated against experimental literature data (Witlox, 2010).

3. Definition of case studies

3.1 Description of the process

In order to illustrate the potentialities of dynamic simulators in consequence assessment, the case study developed by Pannocchia and Landucci (2014) was selected and extended by implementing the set-up described in Section 2. In particular, a three-phase separator was selected in order to perform a consequence assessment, eventually accounting for the effect of protection systems. The PFD of the considered unit is shown in Figure 1; the unit is labelled as VS-1.

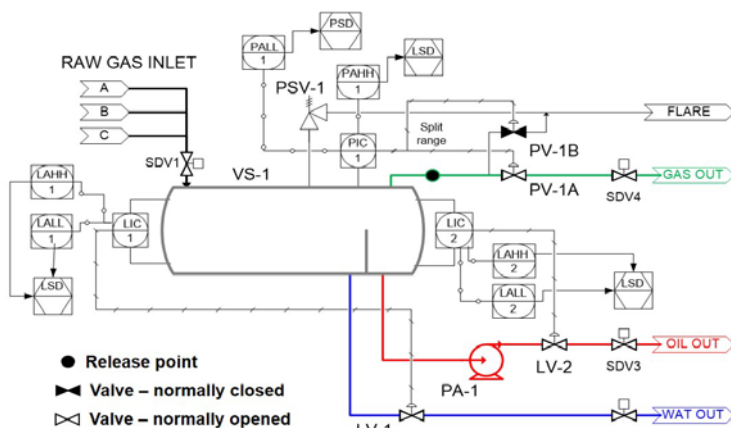

Figure 1. PFD of the separator unit, adapted from (Pannocchia and Landucci, 2014). The scheme indicates the release point considered for the consequence assessment study.

VS-1 receives three inlet streams (namely, A, B and C) featuring hydrocarbon components from C1 to C20+, as well as an aqueous phase containing water and ethylene glycol (EG). The aim of VS-1, which operates at 20 bar and 15°C, is the separation of the gas, the condensate (i.e., the liquid hydrocarbon phase) and the aqueous phase (indicated as “WAT” in Figure 1). More details on the control philosophy and operative conditions of VS-1 are reported elsewhere (Pannocchia and Landucci, 2014); in the following the main details are summarized.

As shown in Figure 1, three main inlet streams (labelled with “A”, “B” and “C”) are collected into an inlet manifold and sent to VS-1. The inlet gas phase is essentially composed by methane (C1) and low molecular weight hydrocarbons (C2-C4), having a total flow rate of about 2,194 kg/h. The condensate flow rate is 28.9×10^3 kg/h, and it is constituted by mainly C5-C20+ hydrocarbons, while the aqueous phase flow rate is 907 kg/h, with a mass ratio water/EG equal to 1.87.

The production separator is operated under split range pressure control PIC-1 on gas phase. However, in this work, it is assumed that the split range control is only activated during start-up and, thus, in normal conditions the line to the flare is excluded. In other words, the valve PV-1B is permanently in closed position (see Figure 1) and the flashed gas is routed to downstream units only through the pressure control valve PV-1A.

3.2 Description of the accidental scenarios

For the process unit described in Section 3.1, an accidental situation is taken as reference to define two case studies. It is assumed that a pressure build up occurs downstream the separator, increasing the pressure in the unit. After 850s, the induced pressure growth leads to accidental damages to gaskets and seals in the vapour exit line, with consequent release of hazardous gas from the separator and jet fire, due to immediate ignition. It is assumed that a hole with 1" (25.4mm) equivalent diameter is formed (see Figure 1 for release point location) and other accidental scenarios are excluded, for the sake of simplicity. Therefore, only two possible situations may evolve based on the possible activation of safety barriers:

- mitigated scenario: the emergency shutdown system correctly activates in about 280s after the release, leading to the isolation of the process unit and mitigated jet fire;
- unmitigated scenario: the emergency shutdown fails on demand, with consequent unmitigated jet fire.

In both cases, the scenario is simulated for a maximum time of 2000s after the beginning of the pressure build up. It is assumed that after this time laps, site emergency response allows for the suppression of the considered scenario (Landucci et al., 2016).

Figure 2 shows the PFD built in UniSim® to analyse the case studies.

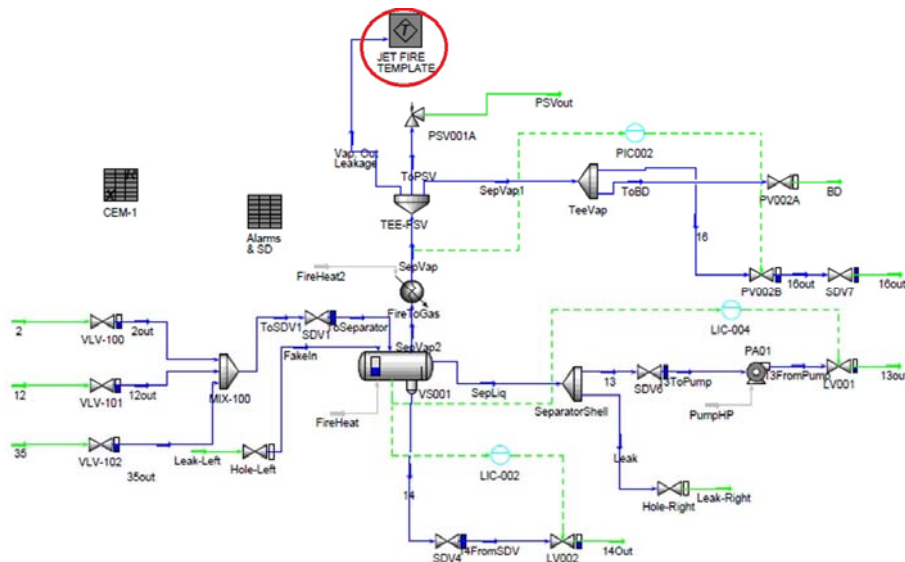

Figure 2. PFD built in UniSim® for the considered unit. The developed template for jet fire simulation is highlighted in red.

As shown in the figure, the template described in Section 2.2 is directly implemented in the subflowsheet ("JET FIRE TEMPLATE" in Figure 2). The template needs to be coupled with a hypothetical stream adopted in UniSim® to simulate the release following the rupture. In particular, as shown in Figure 2, the rupture is simulated introducing a fictitious tee-line in the vapor exit ('Vap. Out Leakage'). The template includes a valve that is opened when the leak starts.

Finally, the same scenario is simulated with PHAST imposing the same initial operating conditions, thus obtaining steady state predictions.

4. Results

Figure 3 shows the results of the case studies obtained through the present approach. Damage distances associated with the threshold values reported in Table 1 are reported in Figures 3a and 3b for the mitigated and unmitigated case, respectively (solid lines). Damage distances are reported as a function of time in order to capture the dynamic evolution of the accident scenario. In Figure 3d, the dashed lines represent the results obtained with PHAST.

Figure 3 also shows the dynamic evolution of the pressure in the separator and the status of either control or shut down valves. These are shown in Figures 3c and 3d for the mitigated and unmitigated case, respectively. As shown in Figure 3c, the release induces a limited but quick depressurization (about 1 bar), hence the control system responds by closing the regulation valve PV-1A. Clearly enough, the depressurization becomes more pronounced when the intervention of emergency shutdown allows for the isolation of the unit, with a residual pressure of 5 bar at the end of the simulation. This induces a relevant decrement in the damage distances (see Figure 3a), which are almost halved, thus with possible reduction in the likelihood of damages to operators.

In the unmitigated case, the separator experiences a quick depressurization (see Figure 3d), which however is slowed due to the failed intervention of the emergency shutdown. In fact, the separator is still connected with upstream and downstream units, thus it is affected by the pressure build up, which leads to the full opening of the pressure control valve PV-1A. Finally, the pressure decreases to about 15 bar. The described pressure behaviour affects the jet fire impact, since the damage distances are almost constant for the entire duration of the fire scenario (see Figure 3b). Hence, severe heat radiation is experienced for a more prolonged time lapse, with possible escalation hazard due to heat up of adjacent units, e.g., such as in the case of fired domino effect (Landucci et al., 2016).

Figure 3b also shows that the damage distances are in good agreement with the prediction of PHAST, especially in the final part of the simulation (e.g., after 1500s from the start of the pressure build up), demonstrating the reliability of the present approach. Clearly enough, due to the decrement in pressure in the mitigated case, due to protections intervention, the results are only comparable with the unmitigated case.

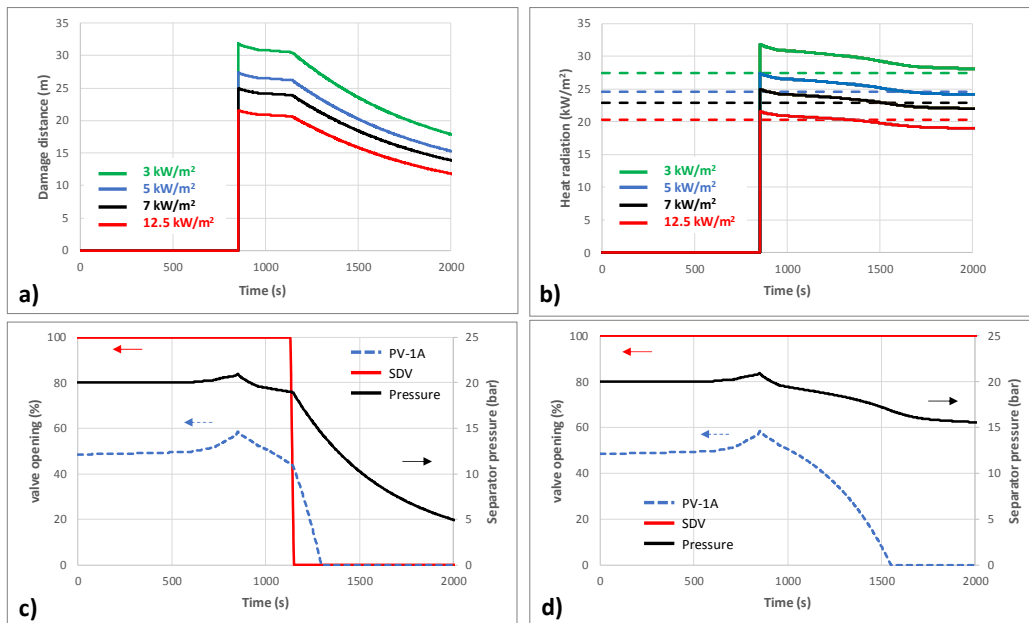

Figure 3. Results of the case studies: damage distances for the mitigated (a) and unmitigated case (b); dynamic evolution of pressure in the separator and status of the control and shut down valves for the mitigated (c) and unmitigated case (d). Dashed lines in panel b represent the results obtained with PHAST. Threshold values for consequence assessment are summarized in Table 1.

5. Discussion

The results shown in Section 4 demonstrated the potentiality of the present approach in supporting advanced QRA studies. The possibility to implement a sound analysis of protection systems, such as emergency isolation systems discussed in the present case, is a relevant improvement in consequence analysis, offering the possibility of implementing mitigated transient scenarios, thus obtaining a more accurate risk evaluation of critical installations. Moreover, the approach may be suitable in the analysis of complex cascading events, such as domino effect (Landucci et al., 2016), with a more accurate estimation of the heat load in equipment affected by fire. In the present work, the analysis focused on far field effects associated with heat radiation. However, a critical issue associated with jet fire consequence assessment is related to flame impingement, especially when dealing with possible domino effect escalation (Gómez-Mares et al., 2008). In fact, the combined radiative and convective contribution, the latter due to the high turbulence induced by the jet, may

cause heat fluxes leading to failure of impinged equipment even in less than 280s (e.g., the time needed for the shut-down activation in the mitigated case). This highlights the key role of passive protections in escalation prevention, such as fireproofing or firewall, i.e., protections that do not require external activation.

Finally, it is worth mentioning that the present method may be extended to other fire types, with dedicated similar templates, or even to include dispersion and explosion scenarios, thus obtaining an innovative tool to support the improvement of QRA studies.

6. Conclusion

In the present work, the potentialities of dynamic process simulators in analysing accidental situations of process units were discussed. In particular, the commercial simulator UniSim® was applied for the analysis of specific case studies in which typical accidental situations, such as equipment pressurization and consequent release of hazardous materials, were considered. The simulator allowed estimating the source term and the physical effects associated with the possible accidental scenarios. The effect of mitigation systems, either in normal or emergency conditions was taken into account, thus allowing for a more accurate prediction of accident impact with respect to conventional approaches based on simplified source term evaluation. The present approach may thus support advanced safety studies, integrating the availability and effectiveness analysis of the protection barriers, thus achieving a more realistic estimation of the risk associated with critical equipment items.

References

- AICHe-CCPS (American Institute of Chemical Engineers Center of Chemical Process Safety), 2000, Guidelines for Chemical Process Quantitative Risk Analysis, AICHe, New York, USA.
- AICHe-CCPS (American Institute of Chemical Engineers Center of Chemical Process Safety), 2001, Layer of protection analysis: simplified process risk assessment, AICHe, New York (NY).
- Brambilla S., Manca D., 2011, Recommended features of an industrial accident simulator for the training of operators, *Journal of Loss Prevention in the Process Industries*, 24, 344–355.
- De Dianous V., Fievez C., 2006, ARAMIS project: A more explicit demonstration of risk control through the use of bow-tie diagrams and the evaluation of safety barrier performance, *Journal of Hazardous Materials*, 130, 220–233.
- Gómez-Mares, M., Zárata, L., Casal, J., 2008, Jet fires and the domino effect. *Fire Safety Journal*, 43, 583–588.
- Honeywell, 2017a, UniSim Design® – User Guide Release R460, Honeywell International Sàrl, Rolle (Switzerland).
- Honeywell, 2017b, UniSim Design® – Dynamic Modeling Reference Guide Release R460, Honeywell International Sàrl, Rolle (Switzerland).
- HSE-Health Safety Executive, 2006, Developing process safety indicators. HSE guidance series, HSG254. Health and Safety Executive, Bootle, United Kingdom.
- Italian Ministry of Public Works, 2001, Requisiti minimi di sicurezza in materia di pianificazione urbanistica e territoriale per le zone interessate da stabilimenti a rischio di incidente rilevante, DM 9 May 2001
- Landucci G., Argenti F., Spadoni G., Cozzani V., 2016, Domino effect frequency assessment: the role of safety barriers. *Journal of Loss Prevention in the Process Industries*, 44, 706-717.
- Lees F.P., 1996, *Loss Prevention in the Process Industries*, 2nd ed., Butterworth Heinemann, Oxford, UK.
- Manca D., Brambilla S., 2009, Dynamic simulation of industrial accidents, *Chemical Engineering Transactions*, 17, 299-304, DOI: 10.3303/CET0917051.
- Manca D., Brambilla S., 2012, Dynamic simulation of the BP Texas City refinery accident, *Journal of Loss Prevention in the Process Industries*, 25, 950–957.
- Pannocchia G., Landucci G., 2014, On the use of dynamic process simulators for the quantitative assessment of industrial accidents, *Chemical Engineering Transactions*, 36, 505-510 DOI: 10.3303/CET1436085
- Shariff M.A., Rusli R., Leong C.T., Radhakrishnan V.R., Buang A., 2006, Inherent safety tool for explosion consequences study, *Journal of Loss Prevention in the Process Industries*, 19, 409–418.
- Uijt de Haag P.A.M., Ale B.J.M., 1999, Guidelines for Quantitative Risk Assessment (Purple Book), Committee for the Prevention of Disasters, The Hague, The Netherlands.
- Van Den Bosh, C.J.H. and Weterings, R.A.P.M., 1997, Methods for the calculation of physical effects (Yellow Book), Committee for the Prevention of Disasters, The Hague, The Netherlands.
- Witlox, H.W.M., 2010, Overview of consequence modelling in the hazard assessment package Phast, 16th Conference on Air Pollution Meteorology, available at <https://ams.confex.com/ams/pdfpapers/163731.pdf>