

PAPER • OPEN ACCESS

Stability of volatile organic compounds in sorbent tubes following SARS-CoV-2 inactivation procedures

To cite this article: Tommaso Lomonaco *et al* 2021 *J. Breath Res.* **15** 037102

View the [article online](#) for updates and enhancements.

You may also like

- [A low cost, easy-to-assemble, open-source modular mobile sampler design for thermal desorption analysis of breath and environmental VOCs](#)
Bradley S Chew, Raquel Pimentel Contreras, Mitchell M McCartney *et al.*
- [Characterization of standardized breath sampling for off-line field use](#)
Sean W Harshman, Rhonda L Pitsch, Christina N Davidson *et al.*
- [Validating a breath collection and analysis system for the new tuberculosis breath test](#)
Amy Scott-Thomas, Michael Epton and Stephen Chambers

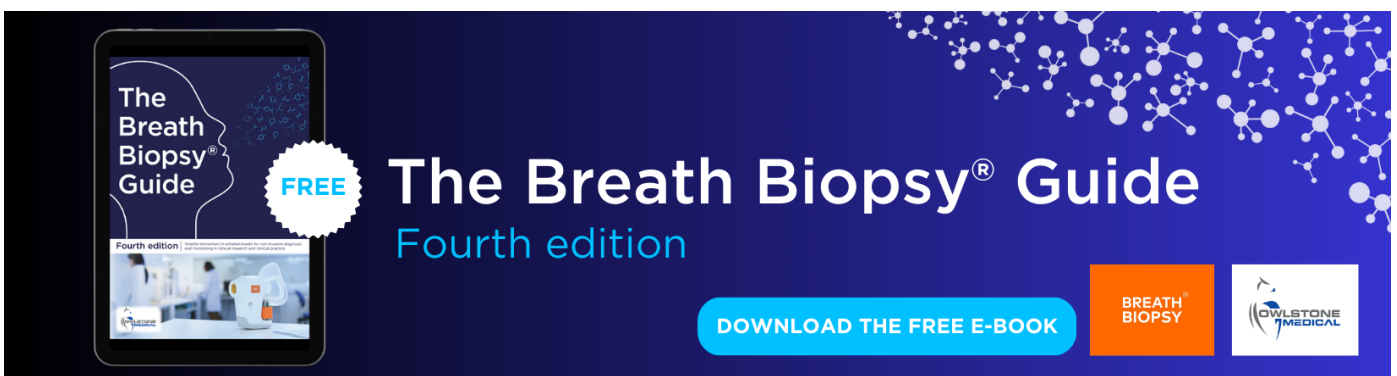

The Breath Biopsy® Guide
Fourth edition

FREE

DOWNLOAD THE FREE E-BOOK

BREATH BIOPSY

OWLSTONE MEDICAL



PAPER

OPEN ACCESS

RECEIVED
12 October 2020REVISED
8 March 2021ACCEPTED FOR PUBLICATION
22 March 2021PUBLISHED
16 April 2021

Original content from this work may be used under the terms of the [Creative Commons Attribution 4.0 licence](#).

Any further distribution of this work must maintain attribution to the author(s) and the title of the work, journal citation and DOI.



Stability of volatile organic compounds in sorbent tubes following SARS-CoV-2 inactivation procedures

Tommaso Lomonaco^{1,*} , Pietro Salvo² , Silvia Ghimenti¹, Denise Biagini¹, Federico Vivaldi¹, Andrea Bonini¹, Roger Fuoco¹ and Fabio Di Francesco¹

¹ Department of Chemistry and Industrial Chemistry, University of Pisa, Pisa, Italy

² Institute of Clinical Physiology, CNR, Pisa, Italy

* Author to whom any correspondence should be addressed.

E-mail: tommaso.lomonaco@unipi.it

Keywords: breath analysis, SARS-CoV-2, thermal inactivation, VOCs, GC-MS

Supplementary material for this article is available [online](#)

Abstract

COVID-19 is a highly transmissible respiratory illness that has rapidly spread all over the world causing more than 115 million cases and 2.5 million deaths. Most epidemiological projections estimate that the Severe Acute Respiratory Syndrome Coronavirus 2 (SARS-CoV-2) virus causing the infection will circulate in the next few years and raise enormous economic and social issues. COVID-19 has a dramatic impact on health care systems and patient management, and is delaying or stopping breath research activities due to the risk of infection to the operators following contact with patients, potentially infected samples or contaminated equipment. In this scenario, we investigated whether virus inactivation procedures, based on a thermal treatment (60 °C for 1 h) or storage of tubes at room temperature for 72 h, could be used to allow the routine breath analysis workflow to carry on with an optimal level of safety during the pandemic. Tests were carried out using dry and humid gaseous samples containing about 100 representative chemicals found in exhaled breath and ambient air. Samples were collected in commercially available sorbent tubes, i.e. Tenax GR and a combination of Tenax TA, Carbograph 1TD and Carboxen 1003. Our results showed that all compounds were stable at room temperature up to 72 h and that sample humidity was the key factor affecting the stability of the compounds upon thermal treatment. Tenax GR-based sorbent tubes were less impacted by the thermal treatment, showing variations in the range 20%–30% for most target analytes. A significant loss of aldehydes and sulphur compounds was observed using carbon molecular sieve-based tubes. In this case, a dry purge step before inactivation at 60 °C significantly reduced the loss of the target analytes, whose variations were comparable to the method variability. Finally, a breath analysis workflow including a SARS-CoV-2 inactivation treatment is proposed.

1. Introduction

About one century after Spanish flu, COVID-19 is making us pay a terrible death toll, deeply modifying our behaviours, causing enormous economic losses, and widening social inequalities [1–3]. After a period of bewilderment and confusion, during which all efforts concentrated on avoiding the collapse of health care systems by using the only possible control measures (e.g. hand hygiene, use of personal protective equipment (PPE), restrictions of movements and social distancing), nations are preparing to live in an

unfortunately unavoidable stage of coexistence with the virus.

Short- and long-term projections are under construction by epidemiologists to get ready for future outbreaks. Although forecasts and timelines vary, on two things modellers agree: COVID-19 is here to stay, and unknowns such as the duration of the immunity, the seasonality effects, and governmental and individual choices will shape our future [4]. With an immunity duration shorter than a year, as for other human coronaviruses, annual surges of infections are assumed until 2025 and beyond [5].

Given the nature and the characteristics of the infection, COVID-19 poses both opportunities and risks for researchers who deal with breath analysis. In fact, the virus causing the infection (Severe Acute Respiratory Syndrome, Coronavirus 2 SARS-CoV-2) is transferred from host to host by respiratory droplets and secretions or by direct contact [6]. The virus infects the respiratory tract and is predominantly expressed in the lungs [6]; however, scientific evidence exists of virus replication in the upper respiratory tract [7]. If volatiles are generated either from virus action or from the reaction of the host to the infection, as *in-vitro* studies with other viruses may suggest [8, 9], these are likely emitted in breath. For this reason, several research groups are trying to develop a fast diagnostic test that would rapidly become a breakthrough application of breath analysis [10].

The success of such a test would depend on many factors, such as the capability for early identification of infected subjects (i.e. still asymptomatic), reliability, speed of response, throughput, and cost. If a breath fingerprint of infected subjects were available, high throughput online instruments (e.g. PTR-TOF, SIFT-MS, and GC-IMS) could deliver quick diagnostic tests wherever needed.

Present competitors, namely molecular and serological tests, have their own strengths and weaknesses [11]. Molecular tests quantify the virus ribonucleic acid (RNA) in nasopharyngeal swabs, from which the occurrence of an active infection and the risk of transmission are inferred. They are mainly based on the reverse transcription-quantitative polymerase chain reaction, a highly selective and specific molecular biology technique combining reverse transcription of RNA into deoxyribonucleic acid (DNA) and the subsequent amplification of specific DNA targets by polymerase chain reaction [12]. Even if it is the gold standard method suggested from the World Health Organization (WHO), it has limitations. All steps must be carried out by highly specialized personnel in the safe conditions of a biosafety level 2 (BLS-2) lab to avoid possible errors (e.g. sample degradation and contamination) and false positives. In addition, it requires relatively expensive and dedicated reagents and equipment. Typically, up to 94 samples can be processed, under optimal conditions, in about 5 h [13].

Serological tests exploit the formation of the antigen-antibody protein bond to detect antibodies produced by the host's immune system in response to a viral infection. However, in the case of SARS-CoV-2 infection, the time required for the immune response to develop is still uncertain and a negative result does not exclude the possibility of an infection at an early stage and the related risk of contagiousness [14]. Additionally, a positive result demonstrates an infection but gives no information about the infection time and subject conditions. The WHO

recommendation is not to take clinical decisions based on immunodiagnostic tests, but to limit their use to epidemiologic research and disease surveillance [15].

So, the unmet demand for a fast, sensitive, but at the same time inexpensive test for the diagnosis of COVID-19 infection and the management of these patients offers a big payback for developers of a diagnostic breath test. However, many in the breath community remain sceptical about the possibility of a breath test to distinguish between different viral infections causing lung inflammation, as emission of the same set of volatile organic compounds (VOCs), such as alkanes, aldehydes, and ketones, is expected [16]. Respiratory infections and lung inflammation caused by bacteria, fungi and other microbial species could also release similar VOCs in breath [17]. More importantly, it is very difficult to imagine how a breath test could identify asymptomatic subjects, who are the most dangerous category because of their ability to unknowingly spread infection in the absence of an apparent lung inflammation, and lead to early identification of infected subjects.

In addition to the opportunity to bring breath analysis to the fore by developing an effective diagnostic test, COVID-19 also brings the remarkable risk of delaying or stopping breath research activity. The breath community should identify procedures to ensure the safety of donors and operators during breath collection and analysis if it does not want to condemn itself to a prolonged stop until the end of the pandemic. In our view, the inclusion of a virus inactivation procedure in the measurement workflow would be quite helpful.

The SARS-CoV-2 virus, responsible for the COVID-19 infection, can survive for 2–3 d on surfaces such as plastic, stainless steel, and copper, although with a titre reduced by more than three orders of magnitude [18]; it can also survive at $-80\text{ }^{\circ}\text{C}$, whereas it is inactivated by chemicals such as ethanol, sodium hypochlorite, and hydrogen peroxide [19]. The authors of a recent review recommend heating objects containing SARS-CoV-2 for 20 min at a temperature above $60\text{ }^{\circ}\text{C}$ for a near complete (4 log_{10}) thermal destruction of the virus [20]. Longer times guarantee a reduced viral load and improve safety. Moreover, the viral load can be also reduced by the same order of magnitude by keeping objects at room temperature for 72 h [18].

The typical protocols used for breath collection are not included among the high-risk aerosol-generating procedures, though there is not an official comprehensive list [21]. In fact, breath collection is typically performed during tidal breathing in which droplet generation is minimal [22]. However, incorrect procedures could modify the ventilation pattern and lead to a marked increase in aerosol generation [23]. Unless previously checked with molecular tests or quarantined, which would be the

optimum condition, breath donors should be managed as if they were infected. Breath collection should be performed in an adequately ventilated room by the absolute minimum number of people required, who should wear the correct PPE, such as medical mask, goggles or face shield, gown and gloves; for specific procedures, respirators and aprons are recommended in guidelines [24]. A detailed description of PPE is beyond the scope of this paper. However, as a rule of thumb, it should cover the whole upper body and be simple to remove after use without contaminating the user. It should also be disposable whenever possible, and disposed of appropriately immediately after use [25].

Many breath collection methods have been proposed in the literature that pose at present different levels of risk [26, 27]. Breath analysis by online instruments does not need specific collection procedures and has a good level of safety, as the transfer lines conveying the sample into the instruments are typically heated and the conditions inside the measurement devices (temperatures close to 40 °C–50 °C and the presence of reactive ions) rapidly inactivate the virus. When sterile and disposable mouthpieces are used, both the breath donor and the researcher wearing appropriate PPE are safe. Breath collection with canisters and polymeric bags (e.g. Tedlar and Nalophan) are problematic for carrying around large volumes of potentially contaminated biological specimens that have to be properly disposed of after analysis. Furthermore, the risk of rupture cannot be excluded for the bags, as well as the risk of spillage during the manipulation needed to transfer sample aliquots to the sorbent devices before the analyses. To minimise these issues, analytical procedures must be carried out in a BLS-2 lab by specialized operators and in accordance with the recommended safety protocols. Virus inactivation procedures are necessary before disposing of the residual sample and recycling (when possible) the collection materials. For this purpose, the usual thermal treatments employed to clean the devices can be applied.

Solid phase extraction (SPE) or needle trap microextraction (NTME) may be considered safe if the transfer of the breath sample into the sorption tube/needle trap is directly performed at collection [28]. After collection, tubes/needles are sealed with caps to avoid spilling or contaminating the sample, and possible contamination of the external surface can be removed by cleaning with an alcoholic solution. Compared to canisters and bags, SPE and NTME produce no waste and also improve the stability of certain analytes (e.g. aldehydes), as recently reported for Tenax TA-based sorbent tubes [29, 30]. On the other hand, a main drawback of sampling bags is their permeability to most compounds [31]. This paper presents a contribution to the development of a safe procedure for breath analysis based on direct sample collection at the sampling site into solid phase

devices such as sorbent tubes, needle traps or solid phase micro-extraction (SPME) fibres, either by self-made or commercial (e.g. ReCIVA) sampling systems. This approach limits sample volume to the minimum amount needed for the analyses and produces minimal contaminated waste. To increase safety, we tested the effect of three virus inactivation procedures (heating to 60 °C for 1 h with or without a dry purge step and storage at 25 °C for 72 h) on the stability of a large number of representative chemicals found in exhaled breath [29, 30, 32, 33] and ambient air [34–37]. We only tested single- and triple-bed sorbent tubes commonly used for off-line breath analysis, but we believe that our results could be extended to the other SPE devices.

2. Materials and methods

2.1. Chemicals and materials

Stock liquid mixture of *C1–C5 alcohols* (methanol, ethanol, 1-propanol, 2-propanol, 1-butanol, 2-butanol, 2-methyl-1-propanol, 2-methyl-2-propanol, 1-pentanol, 2-pentanol, 3-pentanol, 2-methyl-1-butanol, 3-methyl-1-butanol, 2-methyl-2-butanol), *C4–C9 ketones* (2-butanone, 2-pentanone, 3-pentanone, 2-hexanone, 4-heptanone, 3-heptanone, 2-heptanone, 3-octanone, 2-methylcyclohexanone, 3-methylcyclohexanone, 4-methylcyclohexanone, 2-octanone, 5-nonanone, 2-nonanone), *C4–C8 branched ketones* (3-methyl-2-butanone, 3,3-dimethyl-2-butanone, 2-methyl-3-pentanone, 4-methyl-2-pentanone, 2,4-dimethyl-3-pentanone, 2-methyl-3-hexanone, 5-methyl-2-hexanone, 2-methyl-3-heptanone, 5-methyl-3-heptanone, 2,6-dimethyl-4-heptanone, 4-methylpent-3-en-2-one, acetophenone, cyclopentanone, cyclohexanone), 27 *VOCs* (certified reference materials, 0.2 mg ml⁻¹ in methanol: benzene, bromodichloromethane, bromoform, tetrachloromethane, chloroform, chlorobenzene, dibromochloromethane, 1,2-dichlorobenzene, 1,4-dichlorobenzene, 1,2-dichloroethane, 1,1-dichloroethene, *cis*-1,2-dichloroethene, *trans*-1,2-dichloroethene, dichloromethane, 1,2-dichloropropane, ethylbenzene, styrene, tetrachloroethene, toluene, 1,2,4-trichlorobenzene, 1,1,1-trichloroethane, 1,1,2-trichloroethane, trichloroethene, vinyl chloride, *m*-xylene, *o*-xylene, and *p*-xylene) were purchased from AccuStandard, Inc. Chemical Reference Standard (USA). Stock liquid mixture of *C5–C18 n-alkanes* (pentane, hexane, heptane, octane, nonane, decane, undecane, dodecane, tridecane, pentadecane, hexadecane, heptadecane and octadecane) was purchased from Merck. Pure methacrolein, acrolein, 2-methylpropanal, 3-methylbutanal, 2-methylbutanal, acetaldehyde, propanal, butanal, hexanal, heptanal, benzaldehyde, isoprene, acetone, 2-methylpentane, 2,3-butandione, 3-hydroxy-2-butanone, dimethyl sulphide, dimethyl disulphide, and carbon disulphide

were purchased from Fluka, Sigma-Aldrich (Italy). Methanol at HPLC grade was purchased from Merck (Italy). All compounds were at a purity higher than 99%.

Labelled ^8D -toluene was purchased at a purity of 99.8% from ARMAR Chemicals (Switzerland) and used as an internal standard (IS).

Helium 5.6 IP, synthetic air 5.0 IP, and nitrogen 5.0 IP and medical air were purchased from Sol Group Spa (Italy). These gases were further purified with a super clean filter (Agilent Technologies, USA).

A calibration solution loading rig (CSLR, Markes International) and stainless-steel sorbent tubes (O.D. 6.4 mm, I.D. 5 mm, 89 mm length), packed with 250 mg of 60/80 mesh Tenax GR phase (single-bed tubes, SBTs) and with 200 mg of a combination of Tenax TA (60/80 mesh size), Carbograph 1TD (60/80 mesh size) and Carboxen 1003 (40/60 mesh size) (1:1:1) (triple-bed tubes, TBTs), were purchased from Markes International (UK).

A 65 mm aluminium rotameter equipped with a stainless steel float was purchased from Aalborg (USA).

Amber glass vials (1 ml) equipped with screwcap mininert valves were purchased from Sigma-Aldrich (Italy).

A 1 μl syringe was purchased from Hamilton (USA).

A mini-BUCK M-5 primary gas flow calibrator, operating in the range 1–6000 ml min^{-1} , was purchased from A. P. Buck Inc. (USA).

A thermo-hygrometer, equipped with an immersion probe (O.D. 2 mm, 230 mm length) and operating between 5% and 98% relative humidity (RH), was purchased from Delta Ohm (Italy).

The amount of water was estimated from the difference in weight (XP26 microbalance, Mettler Toledo, Italy) before and after gas and vapour sampling or dry purge.

2.2. Preparation of standard solutions

An aliquot (20 μl) of each pure liquid compound was weighed directly into a 1 ml amber glass vial to prepare a stock solution (MIX13). Stock liquid mixtures (i.e. MIX13, C1–C5 alcohols, C4–C7 ketones, C4–C8 branched ketones, 27 VOCs, and C5–C18 n-alkanes) were mixed all together with the IS and then diluted with methanol into a 1 ml vial to prepare a working solution (TMIX) at $\sim 50 \text{ ng } \mu\text{l}^{-1}$ of each target compound. This mixture was immediately stored at 4 °C for 1 month. The *n*-alkane series was also used to calculate the Kovats retention indices for each target compound.

2.3. Preparation of sorbent tubes

SBTs were conditioned at 300 °C for 15 min using a helium flow of 70 ml min^{-1} . TBTs were conditioned using the same He flow rate by applying four temperature steps (100 °C, 200 °C, 300 °C, and 320 °C)

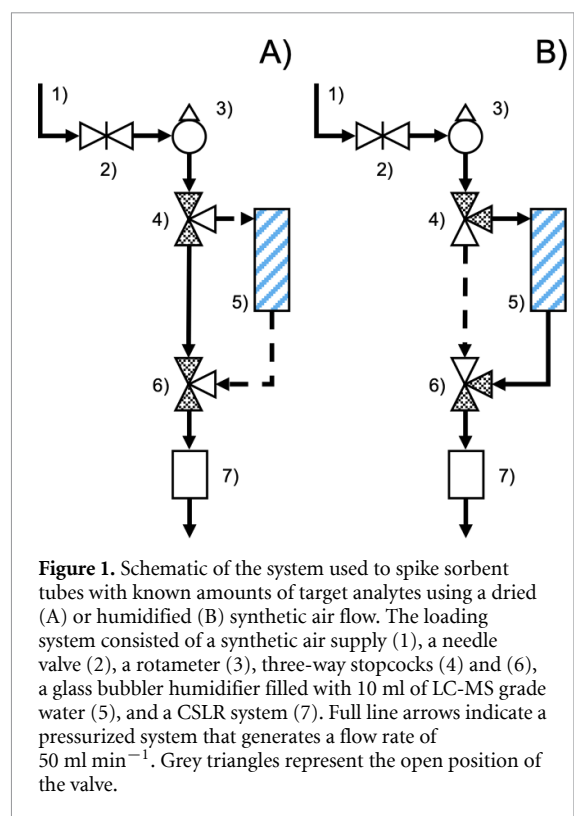

Figure 1. Schematic of the system used to spike sorbent tubes with known amounts of target analytes using a dried (A) or humidified (B) synthetic air flow. The loading system consisted of a synthetic air supply (1), a needle valve (2), a rotameter (3), three-way stopcocks (4) and (6), a glass bubbler humidifier filled with 10 ml of LC-MS grade water (5), and a CSLR system (7). Full line arrows indicate a pressurized system that generates a flow rate of 50 ml min^{-1} . Grey triangles represent the open position of the valve.

for 10 min each. After cleaning, sorbent tubes were capped at both ends with $\frac{1}{4}$ " Swagelok caps, to avoid contamination of the sorbent material, and stored at room temperature (25 ± 2 °C) until use.

A loading system (figure 1) was specifically designed to load a known amount of TMIX in SBTs and TBTs and simulate sampling at different RH values. An aliquot (1 μl) of TMIX was then injected through the injector port of the CSLR system and vaporized by flowing (50 ml min^{-1}) a volume of 250 ml of dried or humidified synthetic air through the tube. The excess methanol was removed by purging the tube.

The loading system was made of inert materials (e.g. polypropylene and polytetrafluoroethylene) to minimize the release of contaminants and the possible loss of target analytes due to chemical interaction with the materials' surface. The needle valve was slightly opened to obtain a flow rate of 50 ml min^{-1} through the sorbent tube. The rotameter was calibrated by plotting the height of the float versus the actual flow rate measured through the sorbent tubes. Each experiment was performed in triplicate.

The RH of the synthetic air flowing out of sorbent tubes was $87 \pm 2\%$ ($n = 5$).

Twenty sorbent tubes (ten of each type) were weighed before (w_b) and after (w_a) spiking known amounts of target analytes (figure 1) as well as after dry purge (w_c). These weights (mean \pm standard deviation) were compared with those obtained when transferring breath samples directly into both SBTs and TBTs ($n = 10$, each type). No statistically significant differences ($p < 0.05$) were observed between the

two groups, confirming the reliability of the proposed procedure for the simulation of breath sampling. Moreover, regardless of the type of tube, w_a-w_b and w_c-w_b were close to zero when tubes were flushed with dry air, whereas w_a-w_b was lower in SBTs than in TBTs flushed with humid air, a logic consequence of the different water retention of sorbent materials ($\sim 2 \text{ mg g}^{-1}$ for Tenax GR and $\sim 400 \text{ mg g}^{-1}$ for Carboxen 1003 [38, 39]). After the dry purge, w_c-w_a was negligible for SBTs and slightly higher than 1 mg for TBTs. This amount of water neither compromises the performance of thermal desorption coupled with gas-chromatography and mass spectrometry (TD-GC-MS) systems nor damages components such as the cold trap, GC column, or MS filament.

2.4. Experimental plan and sample analysis

Three sets of experiments were carried out to test the impact of SARS-CoV-2 inactivation procedures on the stability of target VOCs loaded in SBTs and TBTs by dry and humid air. The presence of water vapour and oxygen in the tube was investigated as it could affect the stability of more reactive species, such as aldehydes [40, 41].

The first set of experiments (SET1) (figure S1(A) (available online at stacks.iop.org/JBR/15/037102/mmedia)) was carried out to assess the effect of inactivation at 60 °C for 1 h. Even though 20 min at 56 °C would have been sufficient for SARS-CoV-2 [20], we increased the temperature and tripled the duration of treatment to stay on the safe side. Tubes were spiked with 1 μl of TMIX while flushed with a stream of dry or humid synthetic air to purge off the excess methanol, then capped at both ends with tight seal caps (Swagelok) or DiffLok caps (Markes International). DiffLok caps contain a helical path (150 mm long and 0.4 mm wide) that preserves the integrity of sample and tube before and after desorption but at the same time allows the removal of VOCs during thermal desorption using Markes' TD instruments. The use of these caps from sample collection (typically performed in hospital) would avoid manipulations of the tubes in the lab, but at the same time puts the stability of analytes at risk due to the possible diffusion of chemicals.

Eighteen sorbent tubes were immediately analysed (reference value), while twelve tubes (six of each type) were capped at both ends with Swagelok caps and six tubes (three of each type) with DiffLok caps before keeping all of them at 60 °C for 1 h and performing the analyses. DiffLok caps were not used in tubes flushed with humid air due to the poor performance observed with dry air (see section 3.2). Each test was performed in triplicate ($n = 3$) for a total of 36 analyses.

The second set of experiments (SET2) (figure S1(B)) aimed to verify the stability of analytes after 72 h at room temperature, conditions which also reduce the viral load to safe levels [18]. In this case,

SBTs and TBTs were spiked with 1 μl of TMIX in both dry and humid conditions. Twelve tubes (six of each tube type) were immediately analysed (reference value), while the remaining tubes (six SBTs and six TBTs) were capped at both ends with Swagelok caps, kept at room temperature (25 ± 2 °C) for 72 h and then analysed. Each test was performed in triplicate ($n = 3$) for a total of 24 analyses.

The third set of experiments (SET3) (figure S1(C)) was used to clarify the effect of water vapour and oxygen contained in the tube on the stability of target analytes. Sorbent tubes (12 of each type) were spiked with 1 μl of TMIX while flowing both dry and humid air. Twelve of them (six of each tube type) were immediately analysed (reference value), while the remaining tubes were dry purged with 50 ml (in the case of single-bed tubes) or 150 ml (in the case of triple-bed tubes) of nitrogen to remove water and oxygen from the sorbent tubes. Tubes were immediately capped at both ends with Swagelok caps, kept at 60 °C for 1 h and then analysed. Each test was performed in triplicate ($n = 3$) for a total of 24 analyses.

Ten conditioned tubes (five of each type) were closed with Swagelok caps. The external surface of each tube (stainless steel) was cleaned with an alcohol-based solution (70% v/v ethanol). Sorbent tubes were analysed to test the possible contamination of the sorbent materials due to cleaning.

All heated sorbent tubes were allowed to reach room temperature before replacing the Swagelok caps with the DiffLok caps required for thermal desorption.

Sorbent tubes were thermally desorbed using a TD-100 multi-tube autosampler equipped with an automated re-collection system (Markes International, UK). Primary desorption was carried out in spitless mode at 300 °C for 8 min by applying a helium flow rate of 35 ml min⁻¹ and keeping the internal focusing trap (70 mg of graphitized carbon) at 5 °C. Secondary desorption was carried out in split mode (split ratio of 11) by heating the cold trap up to 300 °C at 100 °C s⁻¹ for 30 min. During all the TD steps, the flow path temperature was set to 140 °C. The TD unit was directly connected to the GC column via a fused silica transfer line (I.D. 0.25 mm). Analyses were performed using a modified method reported elsewhere [28]. Briefly, a 7890B GC (Agilent Technologies, USA) coupled to a 7010 triple quadrupole mass spectrometer (Agilent Technologies, USA) with an electron ionization source operating at 70 eV was employed. Chromatographic separation was carried out using a DB-5 ms ultra inert capillary column (60 m \times 0.25 mm, 1.0 μm film thickness) from Agilent Technologies (USA) at a constant helium flow of 1 ml min⁻¹. The oven temperature program was: 30 °C for 13 min, 4 °C min⁻¹ to 130 °C (3 min hold time) and 10 °C min⁻¹ to 220 °C (1 min hold time). Post-run time was 15 min with an oven temperature of 250 °C. The triple quadrupole acquired in

both full scan (m/z 30–300) and selected-ion monitoring mode. The temperature of the transfer line, ion source, and quadrupoles were set at 260 °C, 250 °C, and 150 °C, respectively. Helium was used as the quench gas at a flow of 4 ml min⁻¹ and nitrogen as the collision gas at a flow of 1.5 ml min⁻¹. The retention times of the target analytes, qualifier and quantifier ions and qualifier/quantifier (q/Q) ratios are shown in table S1.

2.5. Validation of the TD-GC-MS method

The analytical performance of the TD-GC-MS approach was evaluated by determining carry-over effect, retention capabilities of the sorbent materials, method precision, relative response factors (RRFs), and instrumental detection limit (IDL).

2.6. Data analysis

All data were analysed using GraphPad Prism (v. 8.0) from GraphPad Software Inc. (La Jolla, USA). Statistical significance of differences between groups was evaluated by *t*-tests, and a two-tailed *p*-value of <0.05 was considered significant.

3. Results and discussion

3.1. Analytical performance of the TD-GC-MS method

Figure S2 shows illustrative chromatograms resulting from a working standard gaseous solution (~50 ng μl⁻¹) spiked in both SBTs and TBTs by a humid air stream.

Only a few coelutions were obtained, as those observed between 5-methyl-2-hexanone and chlorobenzene (retention time of 35.45 min) and 2,6-dimethyl-4-eptanon and 4-methylcyclohexanone (retention time of 41.67 min), which were solved by acquiring different m/z ions (table S1).

After conditioning, SBTs and TBTs still released relatively large amounts of benzene and sulphur dioxide, respectively. SBTs also released benzaldehyde and acetophenone at trace level. The thermal desorption efficiency was evaluated by spiking sorbent tubes with ~50 ng of the target analytes under both a dry and humid air stream. The carry-over effect was calculated as the percentage ratio between the peak area measured in the first desorption run and the sum of the peak areas obtained with the first and second desorption runs. As expected, SBTs showed a negligible carry-over effect (<1%) whereas, a memory effect of 5%–10% was observed in the case of TBTs. The retention capability of TBTs was strongly affected by humidity. For example, alcohols showed a decrease of signal in the range 11%–56%, probably due to the competition for the active sites of the less hydrophobic sorbent material (i.e. Carboxen 1003) between water and target analytes [42, 43].

SBTs were less affected by the presence of water vapour in the sample, according to the limited water

retention of Tenax GR, i.e. ~2 mg g⁻¹ of water [38, 39]. In this case, the signal variation was in the range 10%–15%.

Table 1 reports the calibration range, IDL, intra-day (within the same day) and inter-day (on three consecutive days) RRFs, and their corresponding relative standard deviation (RSD) values for the target analytes using SBTs and TBTs loaded under a humid air stream. Method precision was evaluated in triplicate by analysing SBTs and TBTs spiked with ~50 ng of each analyte.

Regardless of the humidity, most analytes showed a method precision in the range 10%–15% and 15%–20% for SBTs and TBTs, respectively. These values comply with the replicate precision level (within 25%) indicated by the compendium method TO-15 EPA [44].

The IDL, evaluated for each analyte as the amount producing a signal-to-noise ratio equal to 3, was in the range 1–10 pg. For all the analytes and sorbent tubes, the RSD values of the RRFs ($A_{\text{analyte}}/A_{\text{IS}} \times m_{\text{IS}}/m_{\text{analyte}}$) was below 30%, indicating a high degree of linearity over the amount range tested [44].

The performance of the TD-GC-MS method was also checked by monitoring the ⁸D-toluene signal over time. A control chart was drawn with the daily average ⁸D-toluene peak areas over 2 months of experiments. The warning limit and the control limit were set at the average value ±1 standard deviation and ±2 standard deviations, respectively. The overall variability was close to 15% for both SBTs and TBTs, confirming that our TD-GC-MS method was highly reproducible and allowed a reliable determination of VOCs in gaseous samples.

Regardless of the humidity, the results highlighted a good stability of the target analytes at about the 50 ng level when SBTs and TBTs were closed with DiffLok caps and kept for 24 h in the TD-100 auto-sampler at room temperature (25 ± 2 °C) to simulate a typical TD-GC-MS sequence.

3.2. Impact of SARS-CoV-2 inactivation treatments on VOC stability

Figures 2 and 3 show the heatmaps that plot the percentage change in the concentration of the target analytes measured in all the experimental tests involving SBTs and TBTs, respectively. The percentage change was calculated with respect to the baseline samples (untreated tube analysed immediately after loading) and are reported in tables S2 and S3.

Use of DiffLok caps to close the sorbent tubes just after the breath sampling in the hospital environment would minimize the handling of the tube by the analyst in the laboratory before the TD-GC-MS analysis and decrease the risk of infection. Unfortunately, results obtained from SET1 experiments (inactivation at 60 °C) revealed that these caps do not guarantee proper storage conditions, since a marked loss (up

Table 1. Calibration range, IDL, intra- and inter-day RRFs and their corresponding RSD values for the target analytes in humid conditions using SBTs and TBTs.

Analyte	Range (ng)	IDL (pg)		Mean RRF (RSD)			
		SBT	TBT	SBT		TBT	
				Intra-day	Inter-day	Intra-day	Inter-day
Vinyl chloride	1.0–50	N.A.	450	N.A.	N.A.	0.01 (14%)	0.01 (16%)
Acetaldehyde	1.5–59	310	170	0.07 (28%)	0.08 (18%)	0.22 (48%)	0.17 (51%)
Ethanol	1.2–47	95	60	0.28 (3%)	0.25 (13%)	0.17 (0%)	0.18 (11%)
Acrolein	1.3–52	15	5	0.07 (15%)	0.07 (18%)	0.50 (6%)	0.54 (10%)
Acetone	0.4–14	3	2	1.40 (3%)	1.23 (16%)	1.75 (11%)	1.77 (7%)
Propanal	0.7–26	10	8	0.48 (2%)	0.44 (10%)	0.47 (14%)	0.47 (9%)
2-Propanol	1.2–47	40	25	0.90 (3%)	0.82 (10%)	0.83 (23%)	0.93 (14%)
Pentane	1.2–46	8	4	0.73 (5%)	0.65 (14%)	0.81 (15%)	0.71 (10%)
Isoprene	0.5–20	150	20	0.05 (6%)	0.04 (20%)	0.46 (24%)	0.44 (17%)
1,1-Dichloroethene	1.3–50	35	25	0.03 (6%)	0.03 (14%)	0.02 (9%)	0.02 (7%)
Dimethyl sulphide	0.5–18	6	6	0.34 (8%)	0.29 (20%)	0.23 (26%)	0.23 (15%)
2-Methyl-2-propanol	1.2–46	3	2	0.62 (6%)	0.56 (13%)	0.42 (5%)	0.45 (7%)
Dichloromethane	1.3–50	20	20	0.03 (5%)	0.03 (11%)	0.02 (26%)	0.02 (16%)
Carbon disulphide	0.9–35	12	10	0.46 (13%)	0.41 (16%)	0.43 (28%)	0.40 (19%)
1-Propanol	1.2–48	90	95	0.16 (3%)	0.15 (12%)	0.09 (22%)	0.11 (16%)
2-Methylpropanal	1.2–46	15	20	0.23 (3%)	0.20 (22%)	0.14 (6%)	0.13 (13%)
2-Methylpentane	0.5–21	12	10	0.29 (8%)	0.25 (18%)	0.20 (11%)	0.21 (8%)
<i>trans</i> -1,2-Dichloroethene	1.3–50	30	25	0.04 (6%)	0.03 (12%)	0.08 (11%)	0.09 (11%)
Methacrolein	1.2–47	120	75	0.17 (1%)	0.15 (15%)	0.03 (27%)	0.03 (18%)
2,3-Butanedione	0.9–35	3	4	0.84 (2%)	0.76 (11%)	0.52 (10%)	0.54 (7%)
Butanal	0.7–28	25	20	0.25 (4%)	0.22 (15%)	0.49 (14%)	0.59 (20%)
2-Butanone	1.2–48	4	3	0.97 (3%)	0.87 (13%)	0.57 (9%)	0.59 (7%)
Hexane	0.7–26	3	6	0.90 (7%)	0.80 (15%)	0.15 (13%)	0.17 (15%)
2-Butanol	1.2–48	3	4	0.55 (5%)	0.48 (15%)	0.36 (18%)	0.36 (11%)
<i>cis</i> -1,2-Dichloroethene	1.3–50	20	25	0.05 (1%)	0.04 (11%)	0.04 (13%)	0.04 (8%)
2-Methyl-1-propanol	1.2–48	7	12	0.10 (3%)	0.09 (7%)	0.08 (10%)	0.15 (15%)
Chloroform	1.3–50	10	12	0.22 (5%)	0.20 (7%)	0.14 (15%)	0.18 (7%)
2-Methyl-2-butanol	1.2–48	2	15	0.53 (4%)	0.48 (14%)	0.08 (10%)	0.08 (17%)
1,1,1-Trichloroethane	1.3–50	25	10	0.18 (4%)	0.17 (12%)	0.29 (22%)	0.32 (17%)
1,2-Dichloroethane	1.3–50	15	20	0.05 (3%)	0.05 (6%)	0.05 (23%)	0.04 (8%)
3-Methylbutanal	1.2–48	10	8	0.29 (3%)	0.26 (13%)	0.33 (11%)	0.38 (18%)
3-Methyl-2-butanone	1.2–48	4	3	0.65 (3%)	0.59 (11%)	0.47 (25%)	0.59 (15%)
Benzene	1.2–49	10	4	0.22 (4%)	0.20 (15%)	0.40 (18%)	0.43 (9%)
1-Butanol	1.2–48	25	40	0.54 (2%)	0.50 (11%)	0.17 (18%)	0.19 (17%)
Tetrachloro methane	1.3–50	25	15	0.05 (4%)	0.05 (10%)	0.20 (17%)	0.20 (14%)
2-Methylbutanal	1.2–48	3	3	0.27 (2%)	0.25 (12%)	0.26 (13%)	0.25 (12%)
2-Pentanone	1.2–48	2	3	1.24 (1%)	1.14 (10%)	0.76 (6%)	0.80 (7%)
3-Pentanone	1.2–49	3	4	0.37 (1%)	0.35 (7%)	0.26 (5%)	0.28 (6%)

(Continued.)

Table 1. (Continued.)

Analyte	Range (ng)	IDL (pg)		Mean RRF (RSD)			
		SBT	TBT	SBT		TBT	
				Intra-day	Inter-day	Intra-day	Inter-day
2-Pentanol	1.2–48	20	15	0.72 (4%)	0.65 (13%)	0.64 (8%)	0.64 (5%)
3-Hydroxy-2-butanone	0.9–36	25	20	0.56 (4%)	0.46 (13%)	0.58 (13%)	0.66 (15%)
Heptane	0.7–28	2	4	0.79 (4%)	0.73 (10%)	0.29 (15%)	0.32 (14%)
3-Pentanol	1.2–49	2	3	0.26 (4%)	0.24 (11%)	0.36 (29%)	0.35 (18%)
Trichloroethene	1.3–50	20	30	0.05 (1%)	0.05 (6%)	0.05 (11%)	0.04 (8%)
1,2-Dichloropropane	1.2–49	80	30	0.15 (0%)	0.14 (8%)	0.28 (8%)	0.31 (9%)
3,3-Dimethyl-2-butanone	1.2–48	3	3	0.41 (1%)	0.37 (10%)	0.42 (17%)	0.53 (19%)
Bromodichloromethane	1.2–49	10	10	0.08 (2%)	0.07 (5%)	0.07 (3%)	0.07 (4%)
3-Methyl-1-butanol	1.2–48	5	4	0.32 (3%)	0.29 (11%)	0.19 (29%)	0.22 (20%)
2-Methyl-1-butanol	1.2–49	5	5	0.34 (3%)	0.31 (12%)	0.20 (26%)	0.23 (19%)
4-Methyl-2-pentanone	1.2–48	2	5	0.54 (2%)	0.49 (12%)	0.35 (4%)	0.38 (9%)
Dimethyl disulphide	0.9–36	1	2	1.11 (2%)	1.01 (11%)	1.23 (11%)	0.95 (9%)
2-Methyl-3-pentanone	1.2–48	6	10	0.24 (3%)	0.22 (8%)	0.54 (22%)	0.61 (17%)
1-Pentanol	1.2–48	15	15	0.31 (5%)	0.28 (13%)	0.19 (22%)	0.20 (16%)
Toluene	1.1–44	1	1	2.66 (2%)	2.49 (8%)	2.14 (0%)	2.15 (0%)
1,1,2-Trichloroethane	0.7–28	20	40	0.08 (1%)	0.09 (5%)	0.06 (1%)	0.06 (3%)
2-Hexanone	1.3–50	2	4	0.68 (2%)	0.70 (11%)	0.56 (1%)	0.60 (8%)
2,4-Dimethyl-3-pentanone	1.2–48	2	3	0.58 (4%)	0.52 (11%)	0.37 (14%)	0.41 (15%)
Cyclopentanone	1.2–48	1	1	0.41 (2%)	0.38 (9%)	0.35 (13%)	0.33 (9%)
4-Methylpent-3-en-2-one	1.4–57	2	2	0.23 (3%)	0.20 (11%)	0.29 (18%)	0.28 (13%)
Octane	1.3–51	1	2	0.95 (2%)	0.89 (9%)	0.62 (6%)	0.63 (4%)
Hexanal	2.7–29	30	20	0.50 (1%)	0.47 (8%)	0.43 (11%)	0.43 (6%)
Dibromochloromethane	1.2–49	15	10	0.08 (1%)	0.08 (4%)	0.08 (5%)	0.07 (8%)
Tetrachloroethene	1.2–49	20	15	0.07 (3%)	0.07 (6%)	0.07 (9%)	0.06 (8%)
2-Methyl-3-hexanone	1.2–50	2	3	0.21 (4%)	0.27 (12%)	0.32 (24%)	0.37 (18%)
5-Methyl-2-hexanone	1.2–49	2	3	0.19 (1%)	0.16 (7%)	0.26 (19%)	0.30 (17%)
Chlorobenzene	1.2–49	1	2	0.52 (4%)	0.47 (14%)	0.44 (12%)	0.54 (7%)
4-Heptanone	1.2–50	6	10	0.26 (3%)	0.24 (11%)	0.26 (26%)	0.34 (17%)
Ethylbenzene	1.3–50	5	6	0.25 (2%)	0.16 (9%)	0.17 (19%)	0.19 (15%)
<i>p</i> -Xylene	1.3–50	7	8	0.20 (4%)	0.19 (11%)	0.19 (14%)	0.18 (11%)
<i>m</i> -Xylene	1.3–50	7	9	0.21 (3%)	0.19 (11%)	0.26 (13%)	0.23 (9%)
3-Heptanone	1.2–49	2	2	0.53 (3%)	0.49 (10%)	0.43 (7%)	0.42 (5%)
2-Heptanone	0.8–49	2	3	0.50 (2%)	0.51 (10%)	0.57 (12%)	0.47 (7%)
Nonane	1.3–30	2	4	0.86 (2%)	0.80 (9%)	0.17 (12%)	0.17 (6%)
Styrene	1.2–50	15	10	0.14 (2%)	0.13 (9%)	0.27 (4%)	0.26 (5%)
<i>o</i> -Xylene	1.2–49	6	7	0.34 (3%)	0.31 (11%)	0.19 (5%)	0.39 (15%)
Heptanal	1.4–49	320	250	0.23 (3%)	0.22 (6%)	0.36 (22%)	0.19 (12%)
Cyclohexanone	1.3–56	2	1	0.34 (0%)	0.31 (11%)	0.31 (21%)	0.35 (3%)
Bromoform	1.2–50	10	2	0.08 (1%)	0.08 (4%)	0.30 (5%)	0.30 (1%)

(Continued.)

Table 1. (Continued.)

Analyte	Range (ng)	IDL (pg)		Mean RRF (RSD)			
		SBT	TBT	SBT		TBT	
				Intra-day	Inter-day	Intra-day	Inter-day
2-Methyl-3-heptanone	1.2–49	3	3	0.38 (0%)	0.35 (11%)	0.37 (2%)	0.41 (18%)
2-Methyl cyclohexanone	1.4–55	15	15	0.48 (3%)	0.33 (11%)	0.58 (24%)	0.47 (4%)
3-Methyl cyclohexanone	1.2–54	15	15	0.46 (1%)	0.42 (11%)	0.45 (2%)	0.43 (10%)
2,6-Dimethyl-4-heptanone	1.4–48	30	25	0.55 (2%)	0.52 (7%)	0.48 (15%)	0.37 (16%)
4-Methyl cyclohexanone	1.4–54	15	15	0.32 (2%)	0.23 (8%)	0.20 (17%)	0.29 (1%)
Benzaldehyde	1.6–62	30	40	0.73 (1%)	0.67 (8%)	0.67 (1%)	0.57 (3%)
2-Octanone	1.2–49	1	1	0.87 (3%)	0.82 (12%)	0.93 (1%)	0.90 (10%)
Decane	1.3–63	1	1	0.13 (2%)	0.15 (6%)	0.22 (10%)	0.19 (21%)
Octanal	1.3–49	1	2	0.17 (8%)	0.16 (19%)	0.20 (23%)	0.18 (11%)
1,4-Dichlorobenzene	1.2–50	15	12	0.17 (1%)	0.16 (7%)	0.18 (10%)	0.17 (5%)
1,2-Dichlorobenzene	1.5–50	15	15	0.15 (1%)	0.20 (7%)	0.23 (9%)	0.23 (8%)
5-Nonanone	1.2–49	2	2	0.94 (4%)	0.84 (12%)	1.08 (5%)	1.02 (5%)
Acetophenone	0.8–61	15	25	0.75 (3%)	0.66 (14%)	0.48 (9%)	0.58 (9%)
2-Nonanone	1.2–49	2	3	0.99 (4%)	0.92 (16%)	0.99 (8%)	0.85 (19%)
Undecane	3.3–2	1	1	0.16 (0%)	0.14 (8%)	0.22 (18%)	0.22 (10%)
Nonanal	1.3–46	5	4	0.44 (7%)	0.41 (19%)	0.36 (9%)	0.35 (5%)
Dodecane	3.3–132	1	1	0.14 (5%)	0.13 (10%)	0.24 (1%)	0.23 (13%)
1,2,4-Trichlorobenzene	1.3–50	10	7	0.65 (3%)	0.54 (15%)	0.78 (13%)	0.72 (6%)
Tetradecane	1.7–69	1	1	0.69 (5%)	0.55 (27%)	0.63 (1%)	0.71 (8%)
Pentadecane	0.9–35	1	1	0.58 (8%)	0.49 (35%)	0.46 (6%)	0.50 (8%)
Hexadecane	1.8–70	2	2	0.63 (6%)	0.51 (27%)	0.57 (0%)	0.46 (4%)
Heptadecane	0.9–35	1	1	0.51 (6%)	0.49 (29%)	0.54 (10%)	0.54 (6%)

N.A. not available.

to 100%) of target analytes was observed using both SBTs and TBTs. We hypothesize that heating at 60 °C leads to a partial desorption and diffusion of the target analytes through the DiffLok cap. Interestingly, the loss was more pronounced for SBTs than TBTs, probably due to the lower retention capability of Tenax GR [45, 46]. The same experiments with Swagelok caps showed that the humidity of the gaseous sample was the key factor affecting the stability of VOCs. In fact, treatment at 60 °C for 1 h of tubes spiked under a dry air stream did not significantly change the concentration of most analytes (figure 2), whose variations were generally within the experimental error (table 1). For example, analyte variations in SBTs ranged between –17% (isoprene) and +18% (acetaldehyde), and in TBTs between –26% (decane) and +22% (5-methyl-2-hexanone).

In the case of tubes loaded by a humid air stream, the stability of VOCs depended on the sorbent materials. In fact, in the case of SBTs most analytes showed variations slightly exceeding the method variability, with a maximum decrease of about 25% for alcohols. Marked decreases (50%–100%) of the amount of many analytes were observed with TBTs, likely due

to the higher hydrophilicity of its sorbent materials compared to SBTs [45, 46]. In fact, Carboxen 1003 retains much more water ($\sim 400 \text{ mg g}^{-1}$) than Tenax GR ($\sim 2 \text{ mg g}^{-1}$) [38, 39]. Surprisingly, the recovered amount of target analytes increased with retention time, suggesting a possible correlation between analyte loss and hydrophobicity of compounds. Recently, Wilkinson *et al* found an inverse correlation between the octanol–water partition coefficient and the percentage recovery of VOCs loaded under a wet versus dry gas stream [47]. The presence of water at 60 °C may enhance the spontaneous oxidation of aldehydes to carboxylic acids [48], promoting a type of on tube oxidation as discussed elsewhere [40]. Such behaviour was confirmed by the presence of carboxylic acids in samples analysed after heating at 60 °C for 1 h. For example, a decrease of butanal in humid samples of 38% corresponded to a concomitant increase of butanoic acid ($\sim 25\%$). Moreover, we found a loss of sulphur-based compounds in SBTs after heating at 60 °C for 1 h. The amount of dimethyl sulphide, carbon disulphide and dimethyl disulphide decreased by about 20% in tubes loaded under both a dry and humid air stream, confirming the difficulties

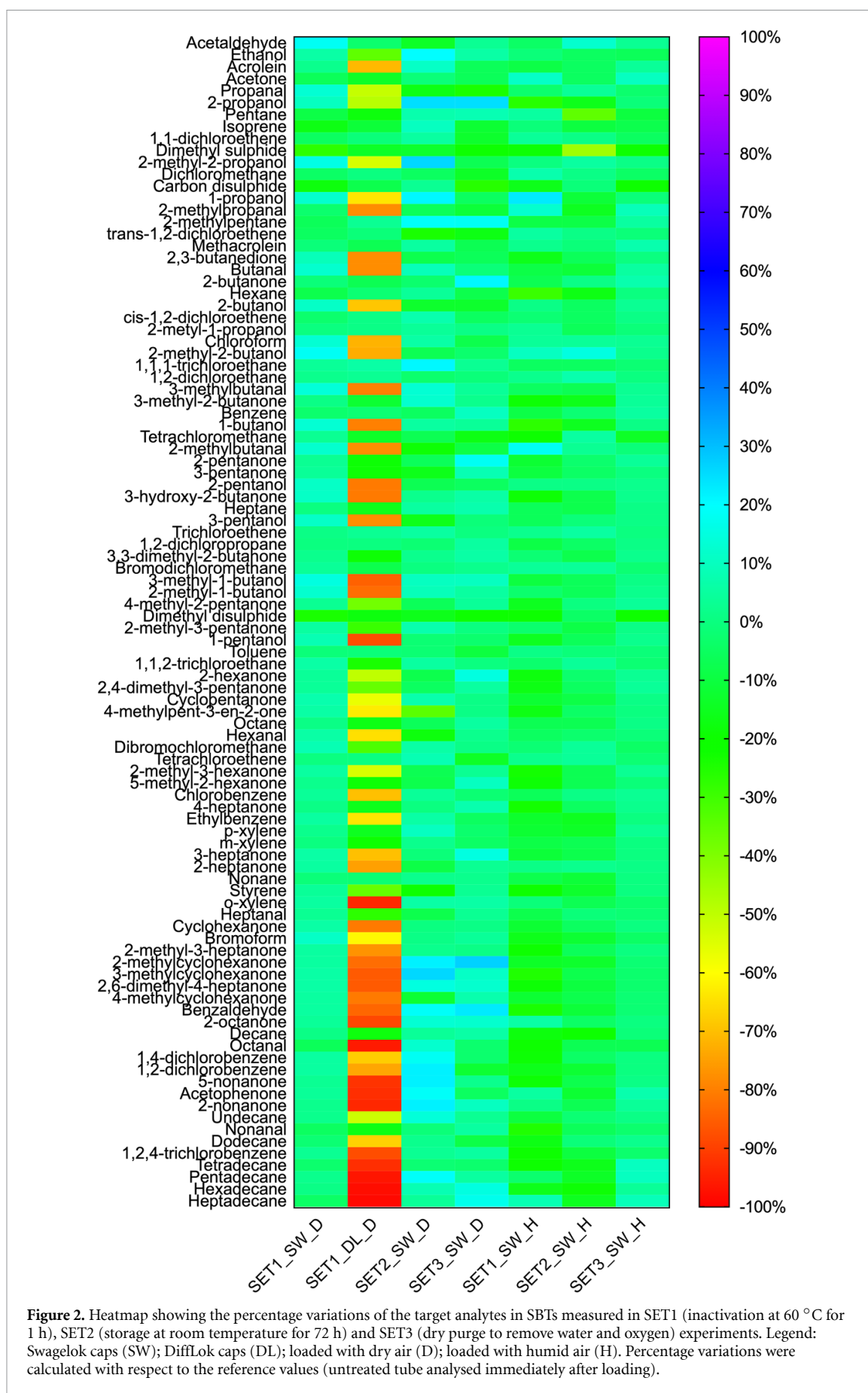

Figure 2. Heatmap showing the percentage variations of the target analytes in SBTs measured in SET1 (inactivation at 60 °C for 1 h), SET2 (storage at room temperature for 72 h) and SET3 (dry purge to remove water and oxygen) experiments. Legend: Swagelok caps (SW); DiffLok caps (DL); loaded with dry air (D); loaded with humid air (H). Percentage variations were calculated with respect to the reference values (untreated tube analysed immediately after loading).

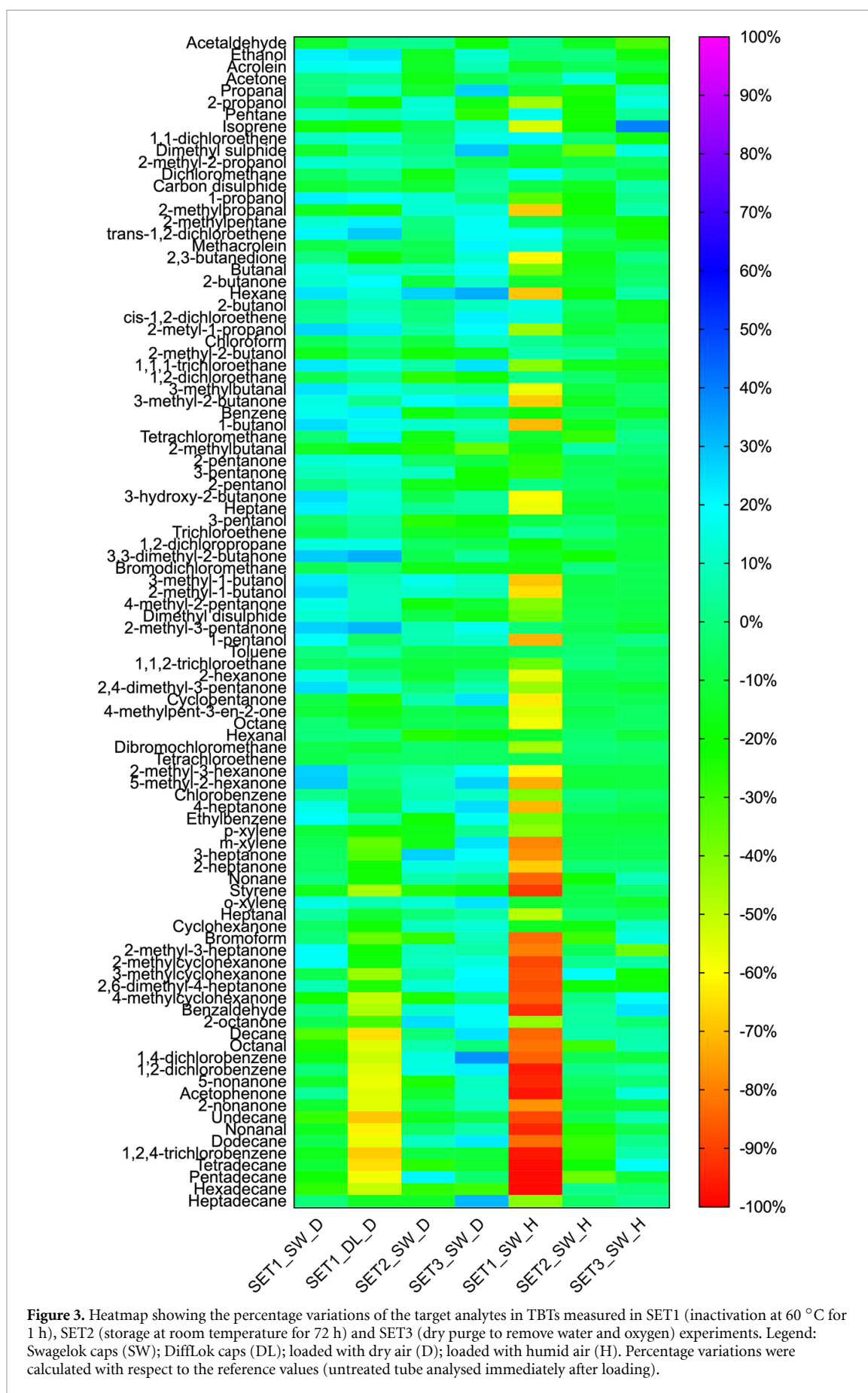

Figure 3. Heatmap showing the percentage variations of the target analytes in TBTs measured in SET1 (inactivation at 60 °C for 1 h), SET2 (storage at room temperature for 72 h) and SET3 (dry purge to remove water and oxygen) experiments. Legend: Swagelok caps (SW); DiffLok caps (DL); loaded with dry air (D); loaded with humid air (H). Percentage variations were calculated with respect to the reference values (untreated tube analysed immediately after loading).

associated with the reliable determination of these compounds in gaseous samples [49, 50]. This behaviour could be due to the high reactivity of sulphur-based compounds [50, 51], as well as to the limited retention capability of Tenax GR at 60 °C [48].

To propose an alternative SARS-CoV-2 inactivation treatment with a lower impact on analyte stability, we carried out two further sets of experiments. In SET2, tubes were stored at room temperature for 72 h to reduce significantly the SARS-CoV-2 viral load (~ 1250 times after 48 h on stainless steel at 21 °C–23 °C [18]). Under these condition, storage did not alter the amount of most chemicals loaded in both types of tube, independent from sample humidity, apart from a few aromatics and ketones (e.g. 1,2- and 1,4-dichlorobenzene and 3-heptanone) whose amounts increased slightly when loaded with dry air. In SET3, a dry purge step was added to remove water and oxygen from the sorbent tubes after loading the sample and reduce reactivity of the retained compounds before raising the temperature to 60 °C for 1 h.

Regardless of the sample humidity, the amounts of the target analytes were not significantly altered when sorbent tubes were stored at ambient temperature for up to 72 h. Our results were generally in agreement with those reported by Harshman *et al* for Tenax TA-based sorbent tubes [40]. These authors evaluated the stability of 74 VOCs in Tenax TA tubes over a period of 31 d by using TD-GC-MS, and concluded that low temperatures (i.e. 4 °C and room temperature) provide the most consistent and reliable conditions to preserve breath samples due to the higher stability of exhaled breath VOCs when compared to higher storage temperatures (37 °C [40]).

In the case of TBTs, the removal of water and oxygen before heating the tubes at 60 °C significantly reduced the loss of the target analytes (figure 3), whose variations were always close to the variability of the analytical method. These latter findings were in accordance with those observed within the first set of experiments of SET1, confirming the key role of the sample humidity in the stability of analytes.

It is worth noting that the use of Swagelok caps to seal sorbent tubes avoided any contamination of the sample when the external surface was cleaned with an alcoholic solution. We did not observe any additional peaks in the GC chromatograms relevant to both SBTs and TBTs.

3.3. Possible breath analysis workflow including a SARS-CoV-2 inactivation treatment

Based on previous findings, we speculate that the inclusion of a SARS-CoV-2 inactivation treatment in the breath analysis workflow may allow off-line measurements to be made safely without decreasing performance. A possible protocol could be:

Step 1: breath is collected into sorbent tubes by an appropriate sampler at the sampling site. This

approach reduces sample volume to the minimum amount needed for the measurement and avoids transportation and storage of biohazardous specimens. The operator wears the correct PPE recommended by guidelines [24] to avoid the risk of infection;

Step 2: sorbent tubes are immediately capped at both ends with tight seal caps and the external surfaces are cleaned with a 70% v/v ethanol solution to remove possible contaminations. Mouthpieces, filters and other consumables in contact with subject's breath are disposed of following the procedures for infected materials, and the breath sampler is thoroughly cleaned for further use;

Step 3: sorbent tubes are either heated at 60 °C for 1 h or kept at room temperature for 72 h to inactivate the SARS-CoV-2 possibly contained within them;

Step 4: sorbent tubes are analysed by routine TD-GC-MS methods.

When sorbent tubes packed with carbon molecular sieves are used, a dry purge step before heating at 60 °C is recommended to preserve the initial chemical composition. A dry purge unit (e.g. TC-20 from Markes International) or a home-made gas line coupled to a mass flow controller are both suitable. For safety reasons, we recommend either performing the dry purge step in a biological cabinet or connecting a second sorbent tube to the sampling tube to block any viral particles conveyed from the gas carrier.

4. Conclusions

Literature reports describe inactivation of SARS-CoV-2 after 20 min at 56 °C or 72 h at room temperature. With the aim of designing a safe protocol to run breath analyses during the pandemic, we investigated the effect of three SARS-CoV-2 inactivation treatments on the stability of a large number of representative compounds of breath and environmental samples collected in single- and triple-bed tubes. Storage of SBTs and TBTs at room temperature did not alter the amount of target compounds. Inactivation at 60 °C for 1 h before the analysis can be used with SBTs, whereas the protocol needs to include a dry purge step to remove water and oxygen before heating in the case of TBTs.

The thermal inactivation procedure at 60 °C reduces the analysis time and can be easily implemented in the clinical setting, but capping of the tubes and cleaning of the external surface with a 70% v/v ethanol solution allow the tubes to be transported to the laboratory without significant risks.

Data availability statement

All data that support the findings of this study are included within the article (and any supplementary files).

Acknowledgments

The authors would like to thank the virologist Professor Fabrizio Maggi for his friendly and helpful suggestions concerning the sterilisation protocols. The authors gratefully acknowledge the financial support of the SMOOTH project (Smart devices for air quality MOnitOring and human health), which received funding from Regione Toscana.

ORCID iDs

Tommaso Lomonaco  <https://orcid.org/0000-0002-1822-7399>

Pietro Salvo  <https://orcid.org/0000-0003-3866-2993>

Fabio Di Francesco  <https://orcid.org/0000-0002-9285-1595>

References

- Nicola M, Alsafi Z, Sohrabi C, Kerwan A, Al-Jabir A, Iosifidis C, Agha M and Agha R 2020 The socio-economic implications of the coronavirus pandemic (COVID-19): a review *Int. J. Surg.* **78** 185–93
- Bowleg L 2020 We're not all in this together: on COVID-19, intersectionality, and structural inequality *Am. J. Public Health* **110** 917–17
- Bonaccorsi G et al 2020 Economic and social consequences of human mobility restrictions under COVID-19 *Proc. Natl Acad. Sci. USA* **117** 15530–5
- Scudellari M 2020 How the pandemic might play out in 2021 and beyond *Nature* **584** 22–5
- Kissler S M, Tedijanto C, Goldstein E, Grad Y H and Lipsitch M 2020 Projecting the transmission dynamics of SARS-CoV-2 through the postpandemic period *Science* **368** 860–68
- Shereen M A, Khan S, Kazmi A, Bashir N and Siddique R 2020 COVID-19 infection: origin, transmission, and characteristics of human coronaviruses *J. Adv. Res.* **24** 91–8
- Wölfel R et al 2020 Virological assessment of hospitalized patients with COVID-2019 *Nature* **581** 465–9
- Schivo M, Aksenov A A, Linderholm A L, McCartney M M, Simmons J, Harper R W and Davis C E 2014 Volatile emanations from *in vitro* airway cells infected with human rhinovirus *J. Breath Res.* **8** 037110
- Aksenov A A, Sandrock C E, Zhao W, Sankaran S, Schivo M, Harper R, Cardona C J, Xing Z and Davis C E 2014 Cellular scent of influenza virus infection *ChemBioChem* **15** 1040–8
- Lamote K, Janssens E, Schillebeeckx E, Lapperre T S, De Winter B Y and Van Meerbeeck J P 2020 The scent of COVID-19: viral (semi-)volatiles as fast diagnostic biomarkers? *J. Breath Res.* **14** 042001
- Kubina R and Dziedzic A 2020 Molecular and serological tests for COVID-19. A comparative review of SARS-CoV-2 coronavirus laboratory and point-of-care diagnostics *Diagnostics* **10** 434–62
- World Health Organization 2020 Laboratory testing for 2019 novel coronavirus (2019-nCoV) in suspected human cases *WHO—Interim Guid*
- Corman V M et al 2020 Detection of 2019 novel coronavirus (2019-nCoV) by real-time RT-PCR *Eurosurveillance* **25** 2000045
- Lee C Y P, Lin R T P, Renia L and Ng L F P 2020 Serological approaches for COVID-19: epidemiologic perspective on surveillance and control *Front. Immunol.* **11** 1–7
- Peeling R W, Wedderburn C J, Garcia P J, Boeras D, Fongwen N, Nkengasong J, Sall A, Tanuri A and Heymann D L 2020 Serology testing in the COVID-19 pandemic response *Lancet Infect. Dis.* **20** E245–E249
- Gould O, Ratcliffe N, Król E and De Lacy Costello B 2020 Breath analysis for detection of viral infection, the current position of the field *J. Breath Res.* **14** 041001
- Graham J E 2013 Bacterial volatiles and diagnosis of respiratory infections *Adv. Appl. Microbiol.* **82** 29–52
- van Doremalen N et al 2020 Aerosol and surface stability of SARS-CoV-2 as compared with SARS-CoV-1 *New Engl. J. Med.* **382** 1564–7
- Han P and Ivanovski S 2020 Saliva—friend and foe in the COVID-19 outbreak *Diagnostics* **10** 1–12
- Kampf G, Voss A and Scheithauer S 2020 Inactivation of coronaviruses by heat *J. Hosp. Infect.* **105** 348–9
- Tran K, Cimon K, Severn M, Pessoa-Silva C L and Conly J 2012 Aerosol generating procedures and risk of transmission of acute respiratory infections to healthcare workers: a systematic review *PLoS One* **7** e35797
- Fabian P, Brain J, Houseman E A, Gern J and Milton D K 2011 Origin of exhaled breath particles from healthy and human rhinovirus-infected subjects *J. Aerosol Med. Pulm. Drug Deliv.* **24** 137–47
- Chandrapalan S, Persaud K C and Arasaradnam R 2020 Breath diagnostics in the era of SARS-CoV-2—in clinical and research arena *J. Breath Res.* **14** 042002
- World Health Organization (WHO) 2020 Rational use of personal protective equipment for coronavirus disease 2019 (COVID-19) *World Health Organ.*
- Cook T M, El-Boghdadly K, McGuire B, McNarry A F, Patel A and Higgs A 2020 Consensus guidelines for managing the airway in patients with COVID-19 *Anaesthesia* **75** 785–99
- Salvo P, Ferrari C, Persia R, Ghimenti S, Lomonaco T, Bellagambi F and Di Francesco F 2015 A dual mode breath sampler for the collection of the end-tidal and dead space fractions *Med. Eng. Phys.* **37** 539–44
- Lawal O, Ahmed W M, Nijssen T M E, Goodacre R and Fowler S J 2017 Exhaled breath analysis: a review of 'breath-taking' methods for off-line analysis *Metabolomics* **13** 1–16
- Biagini D et al 2017 Determination of volatile organic compounds in exhaled breath of heart failure patients by needle trap micro-extraction coupled with gas chromatography-tandem mass spectrometry *J. Breath Res.* **11** 1–14
- De Lacy Costello B, Amann A, Al-Kateb H, Flynn C, Filipiak W, Khalid T, Osborne D and Ratcliffe N M 2014 A review of the volatiles from the healthy human body *J. Breath Res.* **8** 014001
- Shirasu M and Touhara K 2011 The scent of disease: volatile organic compounds of the human body related to disease and disorder *J. Biochem.* **150** 257–66
- Ghimenti S, Lomonaco T, Bellagambi F G, Tabucchi S, Onor M, Trivella M G, Ceccarini A, Fuoco R and Di Francesco F 2015 Comparison of sampling bags for the analysis of volatile organic compounds in breath *J. Breath Res.* **14** 047110
- Amann A, Costello B D L, Miekisch W, Schubert J, Buszewski B, Pleil J, Ratcliffe N and Risby T 2014 The human volatilome: volatile organic compounds (VOCs) in exhaled breath, skin emanations, urine, feces and saliva *J. Breath Res.* **8** 034001
- Broza Y Y, Mochalski P, Ruzsanyi V, Amann A and Haick H 2015 Hybrid volatolomics and disease detection *Angew. Chem., Int. Ed.* **54** 11036–48
- You K W, Ge Y S, Bin H U, Ning Z W, Zhao S T, Zhang Y N and Peng X I E 2007 Measurement of in-vehicle volatile organic compounds under static conditions *J. Environ. Sci.* **19** 1208–13
- Matsumoto K, Matsumoto K, Mizuno R and Igawa M 2010 Volatile organic compounds in ambient aerosols *Atmos. Res.* **97** 124–8
- Dewulf J and Van Langenhove H 1999 Anthropogenic volatile organic compounds in ambient air and natural

- waters: a review on recent developments of analytical methodology, performance and interpretation of field measurements *J. Chromatogr. A* **843** 163–77
- [37] Hung-Lung C, Jiun-Horng T, Shih-Yu C, Kuo-Hsiung L and Sen-Yi M 2007 VOC concentration profiles in an ozone non-attainment area: a case study in an urban and industrial complex metroplex in southern Taiwan *Atmos. Environ.* **41** 1848–60
- [38] Helmig D and Vierling L 1995 Water adsorption capacity of the solid adsorbents Tenax TA, Tenax GR, Carbotrap, Carbotrap C, Carbosieve SIII, and Carboxen 569 and water management techniques for the atmospheric sampling of volatile organic trace gases *Anal. Chem.* **67** 4380–6
- [39] Gawłowski J, Gierczak T, Pietruszowska E, Gawrys M and Niedzielski J 2000 Dry purge for the removal of water from the solid sorbents used to sample volatile organic compounds from the atmospheric air *Analyst* **125** 2112–7
- [40] Harshman S W et al 2016 Storage stability of exhaled breath on Tenax TA *J. Breath Res.* **10** 046008
- [41] Lomonaco T, Romani A, Ghimenti S, Biagini D, Bellagambi F G, Onor M, Salvo P and Fuoco R D F F 2018 Determination of carbonyl compounds in exhaled breath by on-sorbent derivatization coupled with thermal desorption and gas chromatography-tandem mass spectrometry *J. Breath Res.* **12** 046004
- [42] Ho S S H, Chow J C, Watson J G, Wang L, Qu L, Dai W, Huang Y and Cao J 2017 Influences of relative humidities and temperatures on the collection of C2–C5 aliphatic hydrocarbons with multi-bed (Tenax TA, Carbograph 1TD, Carboxen 1003) sorbent tube method *Atmos. Environ.* **151** 45–51
- [43] Trabue S L, Scoggin K D, Li H, Burns R and Xin H 2008 Field sampling method for quantifying odorants in humid environments *Environ. Sci. Technol.* **42** 3745–50
- [44] US EPA 1999 Method TO-15: compendium of methods for the determination of toxic organic compounds in ambient air *EPA Methods* 1–32
- [45] Woolfenden E 2010 Sorbent-based sampling methods for volatile and semi-volatile organic compounds in air. Part 1: sorbent-based air monitoring options *J. Chromatogr. A* **1217** 2674–84
- [46] Woolfenden E 2010 Sorbent-based sampling methods for volatile and semi-volatile organic compounds in air. Part 2: sorbent selection and other aspects of optimizing air monitoring methods *J. Chromatogr. A* **1217** 2685–94
- [47] Wilkinson M, White I R, Goodacre R, Nijssen T M E and Fowler S J 2020 Effects of high relative humidity and dry purging on VOCs obtained during breath sampling on common sorbent tubes *J. Breath Res.* **14** 046006
- [48] Vanoye L, Favre-Réguillon A, Aloui A, Philippe R and De Bellefon C 2013 Insights in the aerobic oxidation of aldehydes *RSC Adv.* **3** 18931–7
- [49] Devai I and Delaune R D 1994 Changes in reduced gaseous sulfur compounds collected in glass gas sampling bulbs *Anal. Lett.* **27** 2403–11
- [50] Wardencki W 1998 Problems with the determination of environmental sulphur compounds by gas chromatography *J. Chromatogr. A* **793** 1–19
- [51] Tangerman A 1986 Determination of volatile sulphur compounds in air at the parts per trillion level by tenax trapping and gas chromatography *J. Chromatogr. A* ([https://doi.org/10.1016/S0021-9673\(01\)93468-5](https://doi.org/10.1016/S0021-9673(01)93468-5))