



- (51) International Patent Classification:
H04W 76/04 (2009.01)
- (21) International Application Number:
PCT/EP2016/060864
- (22) International Filing Date:
13 May 2016 (13.05.2016)
- (25) Filing Language: English
- (26) Publication Language: English
- (71) Applicant: TELECOM ITALIA S.P.A. [IT/IT]; Via Gaetano Negri, 1, I-20123 Milano (IT).
- (72) Inventors: CARETTI, Marco; Telecom Italia S.p.A., Via G. Reiss Romoli, 274, 10148 Torino (IT). NARDINI, Giovanni; Università di Pisa - Dipartimento di Ingegneria dell'Informazione, Via Caruso 16, 56122 Pisa (IT). SA-

BELLA, Dario; Telecom Italia S.p.A., Via G. Reiss Romoli, 274, 10148 Torino (IT). STEA, Giovanni; Università di Pisa - Dipartimento di Ingegneria dell'Informazione, Via Caruso 16, 56122 Pisa (IT). VIRDIS, Antonio; Università di Pisa - Dipartimento di Ingegneria dell'Informazione, Via Caruso 16, 56122 Pisa (IT).

(74) Agent: MACCALLI, Marco et al.; Via Settembrini, 40, I-20124 Milano (IT).

(81) Designated States (unless otherwise indicated, for every kind of national protection available): AE, AG, AL, AM, AO, AT, AU, AZ, BA, BB, BG, BH, BN, BR, BW, BY, BZ, CA, CH, CL, CN, CO, CR, CU, CZ, DE, DK, DM, DO, DZ, EC, EE, EG, ES, FI, GB, GD, GE, GH, GM, GT, HN, HR, HU, ID, IL, IN, IR, IS, JP, KE, KG, KN, KP, KR, KZ, LA, LC, LK, LR, LS, LU, LY, MA, MD, ME, MG, MK, MN, MW, MX, MY, MZ, NA, NG, NI, NO, NZ, OM, PA, PE, PG, PH, PL, PT, QA, RO, RS, RU, RW, SA, SC, SD, SE,

(54) Title: METHOD AND SYSTEM FOR DATA TUNNELING IN DEVICE TO DEVICE COMMUNICATION ASSISTED BY A TELECOMMUNICATION NETWORK

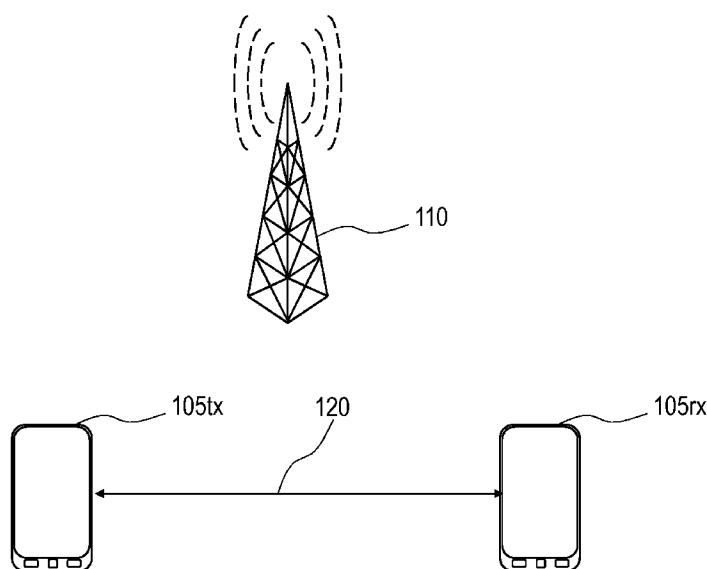

FIG.1B

(57) Abstract: A method for managing data packets (MAC PDU_{tx}, RLC PDU_{tx}) transmitted by a first user equipment (105tx) to be received by a second user equipment (105rx) through a radio network is proposed. The method comprising having the radio network comprising a radio transceiver station (110) configured for receiving data packets (MAC PDU_{tx}; RLC PDU_{tx}) transmitted by the first user equipment. For each data packet received, checking whether the data packet comprises a request for a data packet tunneling (TUN, LCID). For each data packet comprising a request for data packet tunneling, providing the data packet to a relay protocol entity (305) at a Radio Link Control protocol layer (215). The relay protocol entity is configured for generating at least one tunneling data packet (RLC PDU_{eNB}; AM PDU), said generating at least one tunneling data packet comprises inserting at least a



SG, SK, SL, SM, ST, SV, SY, TH, TJ, TM, TN, TR, TT, TZ,
UA, UG, US, UZ, VC, VN, ZA, ZM, ZW.

- (84) Designated States** (*unless otherwise indicated, for every kind of regional protection available*): ARIPO (BW, GH, GM, KE, LR, LS, MW, MZ, NA, RW, SD, SL, ST, SZ, TZ, UG, ZM, ZW), Eurasian (AM, AZ, BY, KG, KZ, RU, TJ, TM), European (AL, AT, BE, BG, CH, CY, CZ, DE, DK, EE, ES, FI, FR, GB, GR, HR, HU, IE, IS, IT, LT, LU, LV, MC, MK, MT, NL, NO, PL, PT, RO, RS, SE, SI, SK, SM, TR), OAPI (BF, BJ, CF, CG, CI, CM, GA, GN, GQ, GW, KM, ML, MR, NE, SN, TD, TG).

Published:

- *with international search report (Art. 21(3))*

METHOD AND SYSTEM FOR DATA TUNNELING IN DEVICE TO DEVICE COMMUNICATION ASSISTED
BY A TELECOMMUNICATION NETWORK

Background of the Invention

5 **Field of the Invention**

The present invention refers to communication systems. More particularly, the present invention relates to the field of wireless or mobile telecommunication networks. Even more particularly, the present invention relates to a system and method adapted to implement a data tunneling in Device-to-Device (D2D) communications assisted by a communication network.

10

Overview of the Related Art

Generally, in a mobile (cellular) telecommunication network, communications among mobile communication devices (e.g., mobile telephones, smartphones and tablets) – generally referred to as User Equipment, or UE in brief – pass through the telecommunication network infrastructure: two UE, connected to
15 respective “serving” radio transceivers of the network (e.g., radio transceivers of a same or different eNodeB - evolved Node B - in the 3GPP Long Term Evolution (LTE)/LTE Advanced (LTE-A) systems), communicate with each other by means of physical communication channel(s) that are set-up and terminated between the radio transceivers and the UE.

As an alternative to communication based on such traditional “2-hop” connection, which hereinafter will
20 be also referred to as Infrastructure Mode (IM) connection, recently UE have been made available that are also capable of communicating directly with each other when they happen to be within a relatively short range.

This direct radio communication among UE is commonly referred to as “Device-to-Device” (D2D) communication based on a Direct Mode (DM) connection, which exploits DM connection links, or sidelinks, directly established between two (or more) UE.

25 DM connection differs from the IM connection in that the information is exchanged through physical communication channels that are set-up and terminated between the UE directly (i.e., comprised in the sidelinks) without passing through the infrastructure of the mobile communication network.

The sidelinks between UE communicating directly among them are generally established over frequencies comprised in a communication frequency range used for the IM connections.

30 Due to mobility of the UE and the necessity of spectrum reuse within the mobile communication network, it is necessary to allow a DM connection to be reverted to an IM connection and back from an IM connection to a DM connection.

In facts, channel conditions on the sidelinks may deteriorate (e.g., because the two UE are moving away from each other), or the same spectrum could be claimed back by the eNodeB to be used for other,
35 communication data flows managed by the latter in order to avoid strong interferences.

In such occurrences, either the current connection may be aborted (disrupting the ongoing communication) or it is switched from DM to IM.

Unfortunately, in conventional mobile communication networks a loss of Protocol Data Units (PDUs, i.e. packets of data outputted by a protocol stack layer) during a mode switch (i.e., a switch from a DM connection to a IM connection or *vice versa*) is unavoidable, since it is due to the Packet Data Convergency Protocol (PDCP) and Radio Link Control (RLC) structure and procedures generally implemented in the mobile communication network.

Generally, three network elements are involved in a mode switch: a transmitter UE, a receiver UE, and an eNodeB managing communications in the cell(s) in which the UE are located.

10 If a D2D communication is ongoing on a sidelink, then the transmitter UE and the receiver UE have a PDCP peering established. In other words, PDCP PDUs (i.e., PDUs generated at the PDCP layer) transmitted by the transmitter UE have a coherent sequence numbering and a consistent ciphering/deciphering keys so that the receiver UE is able to identify and to arrange in a correct order the PDCP PDUs received from the transmitter UE.

15 Conversely, two different PDCP peering must be used in IM connection: one between the transmitter UE and the eNodeB (i.e., the UL leg of the communication), another between the eNodeB and the receiver UE (i.e., the DL leg of the communication).

When a mode switch occurs, a new PDCP peering has to be established, because in IM connection the ciphering/deciphering occurs separately hop-by-hop, and the same set of ciphering/deciphering keys used for the DM connection cannot be used for both the UL and the DL legs of the IM connection in order to avoid communication malfunctions.

Moreover, during a transmission PDCP PDUs are received at the RLC layer of the transmitter UE as RLC Service Data Units (SDU, i.e. packets of data inputted to a protocol stack layer) where they are encapsulated and, possibly segmented, in corresponding RLC PDUs which are passed to the MAC layer for being transmitted.

For this reason, also a peering at the RLC layer has to be established between the transmitter UE and the receiver UE in DM connection, or between the transmitter UE and the eNodeB and between the latter and the receiver UE in IM connection.

Accordingly, the sequence numbers of RLC PDUs cannot be assumed to be synchronized after a mode switch from a DM connection to an IM connection or *vice versa*, i.e. the sequence numbers of RLC PDUs of the DM connection is not synchronized with the sequence numbers of RLC PDUs of the UL or the DL legs of the IM connection.

Particularlry, RLC PDUs received by the receiver UE during a DM connection have different sequencing number and ciphering/deciphering keys with respect to RLC PDUs received by the receiver UE during an IM connection.

Having separate RLC peering (i.e., synchronization between transmitting and receiving network elements) for the DM and the IM connections implies that, after a mode switch, each RLC PDU in the transmitter UE that is waiting to be transmitted according to the “old” peering (e.g., RLC PDUs generated to be transmitted through a DM connection) is completely useless, not being correctly identified at the receiver UE and is discarded.

In addition, each RLC PDU already generated for being transmitted according to the “old” peering cannot be transmitted according to the “new” peering (e.g., RLC PDU generated to be transmitted through an IM connection), since the RLC PDU is already ciphered using the wrong ciphering keys (i.e., the ciphering keys for the DM connection are generally different than that used for the IM connection).

Moreover, segments of RLC SDUs (encapsulated in corresponding RLC PDUs) that have been already received at the receiver UE at the time of the mode switch are to be discarded as well (i.e., at least at the expiry of a RLC reassembly timeout of the receiver UE), since their missing counterparts, buffered at the transmitter UE according to the “old” peering, cannot be correctly received as described above.

Such losses may have heavy repercussions on communication effectiveness.

For example, UDP-based multimedia flows, such as video or voice data streams, are highly sensitive to losses, which impair the quality of experience of the final user.

Similarly, TCP-based applications are extremely sensitive to losses, which are treated by TCP protocol as congestion signals, thereby reducing the congestion window and thus the throughput. Thus, several TCP applications perceiving a(n alleged) congestion signal simultaneously cause a major, long-lasting and unnecessary reduction of aggregate (cell) throughput.

Handover procedures cannot be effectively implemented during mode switches, since they would imply high latencies.

In addition, it should be noticed that mode switches may be frequent (e.g., in the order of few seconds) according to UE movement and resource availability of the mobile communication network, i.e. generally much more frequent than handovers between eNodeBs, and – unlike the latter – may interest several data flows at the same time, possibly the data flows occurring within an entire cell managed by an eNodeB, since switching a data flow from the DM connection to the IM connection (or *vice versa*) may have far-reaching consequences on other data flows provided within the same (and possibly neighboring) cell(s).

Therefore, handover techniques implemented in DM-IM connection mode switching would also sensibly complicating the management of the whole mobile communication network.

It should be noted that the terms “mode switching” and “DM-IM connection mode switching” are herein used, for the sake of conciseness to denote both switching from a DM connection to an IM connection and, *vice versa*, switching from an IM connection to a DM connection in a communication between UE.

In the art some expedients for mitigating issues related to DM-IM connection mode switching have been proposed.

For example, WO 2014/068464 discloses a method, an apparatus and a computer program product for enabling a D2D bearer to stay alive even in an instance in which a D2D connection is lost. A method is provided that comprises detecting a condition that indicates that a device-to-device bearer is to be terminated. The method may also include modifying a cellular bearer protocol data unit header, such that the cellular bearer protocol data unit header indicates that a cellular bearer service data unit is a device-to-device protocol data unit. The method of this embodiment may also include causing one or more device-to-device protocol data units to be encapsulated within one or more cellular bearer protocol data units, such that the one or more device-to-device protocol data units are transmitted via a cellular bearer.

10 Summary of the Invention

The Applicant has observed that, generally, the expedients known in the art are not able to provide for a satisfactory transition between DM and IM connections and *vice versa* between IM and DM connections during a communication between UE.

Particularly, the applicant has noted that the expedients proposed in WO 2014/068464 may increase latency and introduce excessive overhead which would sensitively lower an effectiveness of the communication between UE.

The Applicant has therefore tackled the problem of how to implement Device-to-Device (D2D) communications and integrate D2D communications in a mobile communication network framework in a lossless and effective way.

Further, the Applicant has tackled the problem of how to implement a mode switching between Direct Mode (DM) to Infrastructure Mode (IM) connections and *vice versa* with minimal modifications to the protocol stack.

The Applicant has further tackled the problem of implementing DM-IM connection mode switching operating at one or more predetermined layers of protocol layers in a way that is transparent to the upper protocol layers of the receiver.

Particularly, one aspect of the present invention proposes a method for managing data packets transmitted by a first user equipment to be received by a second user equipment through a radio network is proposed. The method comprising having the radio network comprising a radio transceiver station configured for receiving data packets transmitted by the first user equipment; for each data packet received, checking whether the data packet comprises a request for a data packet tunneling; for each data packet comprising a request for data packet tunneling, providing the data packet to a relay protocol entity at a Radio Link Control protocol layer. The relay protocol entity is configured for generating at least one tunneling data packet, said generating at least one tunneling data packet comprises inserting at least a portion of the transmitted data packet into the at least one tunneling data packet and transmitting the tunneling data packet to the second user

equipment.

Preferred features of the present invention are set in the dependent claims.

In one embodiment of the present invention, receiving data packets transmitted by the first user equipment comprises receiving Medium Access Control data packets at a Medium Access Control protocol layer, each Medium Access Control data packet comprising a header portion and a payload portion. In addition, checking whether the data packet comprises a request for a data packet tunneling comprises checking whether the header of each Medium Access Control data packet comprises the request for a data packet tunneling.

In one embodiment of the present invention, checking whether the header of each Medium Access Control data packet comprises a request for a data packet tunneling comprises checking a value of a predetermined reserved bit comprised in the header of the Medium Access Control data packet.

In one embodiment of the present invention, checking whether the header of each Medium Access Control data packet comprises a request for a data packet tunneling comprises checking a value of a predetermined sequence of bits comprised in the header of the Medium Access Control data packet.

In one embodiment of the present invention, the payload of the Medium Access Control data packet comprises at least a portion of a Radio Link Control data packet. In addition, generating at least one tunneling data packet comprises generating at least one Radio Link Control tunneling data packet at the Radio Link Control protocol layer, said generating at least one Radio Link Control tunneling data packet comprises inserting at least a portion of the Radio Link Control data packet into the at least one Radio Link Control tunneling data packet.

In one embodiment of the present invention, the Radio Link Control tunneling data packet comprises a tunneling header portion and a tunneling payload portion. In addition, generating at least one Radio Link Control tunneling data packet comprises inserting the at least a portion of the Radio Link Control data packet in the payload of the at least one Radio Link Control tunneling data packet.

In one embodiment of the present invention, the Radio Link Control data packet comprises a header portion and a payload portion. In addition, the header portion of the Radio Link Control data packet comprises an indication of a position in a sequence of Radio Link Control data packets thereof, and the tunneling header portion of the Radio Link Control tunneling data packet comprises an indication of a tunneling position in a sequence of Radio Link Control tunneling data packets thereof. Advantageously, the indication of a position is different from the indication of a tunneling position.

In one embodiment of the present invention, transmitting the tunneling data packet to the second user equipment comprises generating a Medium Access Control data packet, the Medium Access Control data packet comprising a header portion and a payload portion, wherein the header of the Medium Access Control data packet comprising an indication that a tunneling of data packets has been implemented, and the payload of the Medium Access Control data packet comprises the at least one Radio Link Control tunneling data packet, and transmitting the Medium Access Control data packet to the second user equipment.

In one embodiment of the present invention, generating at least one tunneling data packet, comprises generating at least one tunneling data packet as at least one Acknowledge Mode data packet, and inserting at least a portion of the transmitted data packet into the at least one Acknowledge Mode data packet.

In one embodiment of the present invention, the transmitted data packet comprises a Radio Link Control data packet, the Radio Link Control data packet comprising an indication of a position in a sequence of Radio Link Control data packets thereof. In addition, generating at least one tunneling data packet as at least one Acknowledge Mode data packet comprises setting an indication of a position in a sequence of Acknowledge Mode data packets of the Acknowledge Mode data packet equal to the indication of a position in a sequence of Radio Link Control data packets comprised in the Radio Link Control data packet.

In one embodiment of the present invention, inserting at least a portion of the transmitted data packet into the at least one Acknowledge Mode data packet comprises segmenting the Radio Link Control data packet in two or more segments; for each segment of the Radio Link Control data packet inserting the segment of the Radio Link Control data packet in a respective Acknowledge Mode data packet, and providing in the Acknowledge Mode data packet an indication of a position of the segment of the Radio Link Control data packet in the Radio Link Control data packet of which is part.

Another aspect of the present invention proposes a further method for managing data packets transmitted by a first user equipment to be received by a second user equipment. The method comprising having the second user equipment configured for receiving data packets transmitted by the first user equipment or by a radio transceiver station of a radio network; for each data packet, checking whether the data packet comprises an indication of the implementation of a data packet tunneling; for each data packet comprising an indication of the data packet tunneling, providing the data packet to a tunneling receiver protocol entity at a Radio Link Control protocol layer. The tunneling receiver protocol entity being configured for extracting at least a portion of a tunneled data packet from said data packet, and providing the at least a portion of a tunneled data packet to a receiver protocol entity at the Radio Link Control protocol layer.

In one embodiment of the present invention, receiving data packets transmitted by the first user equipment or by a radio transceiver station of a radio network comprises receiving Medium Access Control data packets at a Medium Access Control protocol layer, each Medium Access Control data packet comprising a header portion and a payload portion. In addition, checking whether the data packet comprises an indication of the data packet tunneling comprises checking whether the header of each Medium Access Control data packet comprises the indication of the data packet tunneling.

In one embodiment of the present invention, checking whether the header of each Medium Access Control data packet comprises a request for a data packet tunneling comprises checking a value of a predetermined reserved bit comprised in the header of the Medium Access Control data packet.

In one embodiment of the present invention, checking whether the header of each Medium Access Control data packet comprises a request for a data packet tunneling comprises checking a value of a

predetermined sequence of bits comprised in the header of the Medium Access Control data packet.

In one embodiment of the present invention, the payload portion of the Medium Access Control data packets comprises a Radio Link Control tunneling data packet. In addition, extracting at least a portion of a tunneled data packet from said data packet comprises extracting at least a portion of a Radio Link Control data packet generated by the first user equipment from the Radio Link Control tunneling data packet.

In one embodiment of the present invention, said Radio Link Control tunneling data packet comprises a header portion and a payload portion, the at least a portion of a Radio Link Control data packet) generated by the first user equipment being comprised in said payload portion of the Radio Link Control tunneling data packet.

In one embodiment of the present invention, the header portion of the Radio Link Control tunneling data packet comprises an indication of a position in a sequence of Radio Link Control tunneling data packets thereof. In addition, providing the at least a portion of a tunneled data packet to a receiver protocol entity at the Radio Link Control protocol layer comprises reconstructing a Radio Link Control data packet by combining portions of the Radio Link Control data packet contained in the payload of Radio Link Control tunneling data packet comprising indications of adjacent positions in a sequence of Radio Link Control tunneling data packets.

Another aspect of the present invention proposes a still further method for managing data packets transmitted by a first user equipment to be received by a second user equipment. The method comprises having the first user equipment configured for generating data packets; transmitting the data packets to the second user equipment or to a radio transceiver station of a radio network. Advantageously, generating data packets comprises providing a request for a data packet tunneling in data packets to be transmitted to the radio transceiver station.

In one embodiment of the present invention, generating data packets comprises generating Medium Access Control data packets at a Medium Access Control protocol layer, each Medium Access Control data packet comprising a header portion and a payload portion. In addition providing a request for a data packet tunneling comprises providing a request for a data packet tunneling within the header of Medium Access Control data packets.

In one embodiment of the present invention, providing a request for a data packet tunneling within the header of Medium Access Control data packets comprises providing a request for a data packet tunneling within the header of Medium Access Control data packets by setting a value of a predetermined reserved bit comprised in the header of the Medium Access Control data packet.

In one embodiment of the present invention, providing a request for a data packet tunneling within the header of Medium Access Control data packets comprises providing a request for a data packet tunneling within the header of Medium Access Control data packets by setting a value of a predetermined sequence of bits comprised in the header of the Medium Access Control data packet.

In one embodiment of the present invention, providing a request for a data packet tunneling in data packets to be transmitted to the radio transceiver station comprises providing a request for a data packet

tunneling in data packets to be transmitted to the radio transceiver after switching from a Direct Mode connection in which data packets are transmitted directly to the second user equipment to an Infrastructure Mode connection in which data packets are transmitted to the second user equipment through the radio transceiver station of the radio network.

5 Another aspect of the present invention proposes a radio network comprising a radio transceiver station arranged for managing data packets transmitted by a first user equipment to be received by a second user equipment, the radio transceiver station comprising hardware, firmware, a combination of hardware and software, or software configured for implementing the method of above.

10 Another aspect of the present invention proposes a user equipment arranged for transmitting to and/or receiving from a further user equipment data packets by means of a Direct Mode connection in which data packets are directly transmitted to and/or received from the further user equipment or by means of an Infrastructure Mode connection in which data packets are transmitted to and/or received from the user equipment and the further user equipment through a radio transceiver station of a radio network, the user equipment comprising hardware, firmware, a combination of hardware and software, or software configured for
15 implementing the method of above.

Brief Description of the Drawings

These and others features and advantages of the solution according to the present invention will be better understood by reading the following detailed description of an embodiment thereof, provided merely by
20 way of non-limitative example, to be read in conjunction with the attached drawings, wherein:

Figure 1A is a radio network arrangement in which two User Equipment communicate through an Infrastructure Mode connection;

Figure 1B is a radio network arrangement in which two User Equipment communicate through a Direct Mode connection;

25 **Figure 2** schematically shows a portion of a protocol layer stack;

Figure 3A illustrates protocol entities implemented at the RLC layer of an eNodeB according to an embodiment of the invention;

Figure 3B illustrates protocol entities implemented at the RLC layer of a UE according to an embodiment of the present invention;

30 **Figure 4** schematically shows a portion of a header of a generic MAC PDU;

Figures 5A and **5B** schematically shows some stages of a communication based on a DM connection according to an embodiment of the invention;

Figures 6A to **6E** schematically shows some stages of a communication based on an IM connection according to an embodiment of the invention;

35 **Figure 7** schematically shows a structure of a generic RLC Acknowledge Mode PDU;

Figure 8 is a plot of a TCP congestion window as a function of time for a radio network arrangement implementing a mode switching according to an embodiment of the present invention and of a known solution, and

Figure 9 is a schematic bar chart comparing a throughput achieved by a radio network arrangement implementing the mode switching according to an embodiment of the present invention with a throughput achieved by a radio network arrangement implementing TCP congestion control algorithm known in the art.

Detailed Description of the Invention

With reference to the drawings, **Figures 1A** and **1B** is a radio network arrangement in which two User Equipment, or UE **105** (e.g., a smartphone, a tablet, a laptop/notebook, etc.), communicate through an Infrastructure Mode, or IM, connection and through a Direct Mode, or DM, connection, respectively.

In the IM connection (as shown in **Figure 1A**), a transmitter UE **105tx** establishes an uplink, or UL, 'leg' **115ul** of the connection with a respective "serving" radio transceiver station of the radio network, e.g. an evolved Node B, eNB **110** in 3GPP Long Term Evolution (LTE)/LTE Advanced (LTE-A) systems, and transfers communication data (e.g. data packets) to be received by a receiver UE **105rx** to the eNB **110**. Then, the eNB **110** transmits the data packets to the receiver UE **105rx** by establishing a downlink, or DL, leg **115dl** of the connection with the receiver UE **105rx**.

Conversely, in DM connection (as shown in **Figure 1B**) the transmitter UE **105t** transfers communication data directly to the receiver UE **105rx** by establishing a sidelink **120** with the latter.

During communication, user and control data to be transmitted by the transmitter UE **105tx** are processed by the packet data convergence protocol (PDCP), the radio link control (RLC) protocol and the medium access control (MAC) protocol, before being passed to the physical layer for (radio) transmission.

For example, by making reference to **Figure 2** that is a schematic representation of a portion of the protocol layer stack **200**, the transmission of data packets proceeds in the following manner.

At the transmitter UE **105tx**, information data generated at higher protocol layers (e.g., by software applications) descends the protocol stacks being processed substantially at each layer before being transmitted. Particularly, after being processed at an Internet Protocol (IP) Layer **205**, data are received at a PDCP layer **210**. Particularly, data belonging to a data flow are subdivided in data packets, which are denoted to as PDCP Service Data Units, or SDUs received at the PDCP layer **210**. It should be noted that data packets received at a protocol layer are generally called Service Data Unit (SDU).

At the PDCP layer **210** PDCP Packet Data Units, or PDUs (PDU is generic name for data packet outputted by a layer) are generated, e.g. by segmenting and/or otherwise processing PDCP SDUs previously received. The PDCP PDUs are sent to a RLC layer **215** where are received as corresponding RLC SDUs.

At the RLC layer **215**, RLC SDUs are segmented and processed thus producing corresponding RLC PDUs. The RLC PDUs are submitted to a MAC layer **220** (where are considered as MAC SDUs).

At the MAC layer **220** a MAC header is added to the MAC SDUs and a padding may be implemented to fit MAC SDUs in Transmission Time Interval, or TTI. Afterwards, MAC PDU are transferred to a physical layer **225** for being transmitted onto physical channels.

Similarly, (transmitted) data received at the physical layer of the receiver UE **105r** are processed by the layers of the protocol stack, particularly the medium access control (MAC) protocol, the radio link control (RLC) protocol and packet data convergence protocol (PDCP), before the user and control data are passed to higher layer of the protocol stack (applying substantially the same procedures just described in a reverse order as described in the following).

Particularly, both at the PDCP and RLC layers the respective PDCP PDUs and RLC PDUs are generally ciphered by means of respective ciphering keys and numbered in order that the PDUs may be ordered in a sequence (and thus correctly reconstruct data therein contained) once received at the receiver UE **105rx**.

In a DM connection, the transmitter UE **105tx** and receiver UE **105rx** have PDCP and RLC peering established – i.e., ciphering keys and sequence numbers used by the transmitter UE **105tx** are known by the receiver UE **105rx** –, in order to allow the receiver UE **105rx** to correctly order and decipher the PDUs sent by the transmitter UE **105tx**.

Conversely, in an IM connection an uplink (UL) peering is established between the transmitter UE **105tx** and the eNB **110**, while a downlink (DL) peering is established between the eNB **110** and the receiver UE **105rx**. The UL peering exploits different sequencing numbers and ciphering/deciphering keys for PDUs transmitted by the transmitter UE **105tx** than the sequencing numbers and ciphering/deciphering keys for PDUs transmitted by the eNB **110** exploited in DL peering.

In an embodiment of the invention, during an IM connection the RLC PDU generated by the transmitter UE **105tx** and received at the eNB **110** (i.e., through a UL leg of the IM connection) are directly forwarded to the receiver UE **105rx** by the eNB **110** (i.e., through a DL leg of the IM connection) without being passed to, and therefore processed at, higher protocol layers (e.g., PDCP layer and higher level layers).

In an embodiment of the invention, the RLC PDU generated by the transmitter UE **105tx** once received at the eNB **110** in the IM connection are tunneled in a 'tunneling' RLC PDU at the RLC layer **215**.

The term 'tunneling' is herein used for indicating the insertion of one or more data packet, and/or a portion of data packet into another data packet performed at a same protocol layer of the protocol layers stack. In the non-limiting embodiment of the present invention herein described, one or more RLC PDUs and/or a portion of a RLC PDU (i.e., a data packet associated with the RLC layer) are inserted into a further RLC PDU (i.e., a further data packet associated with the RLC layer).

Thanks to the tunneling of RLC PDUs according to the embodiments of the invention, mode switching from DM connection to IM connection and/or from IM connection to DM connection is performed substantially in a lossless way, i.e. ensuring an effective communication between the transmitting UE **105tx** and the receiving

UE **105rx** substantially regardless a number and frequency of connection mode switching that may occur during the communication.

Figures 3A and **3B** illustrate protocol (operating) entities implemented at the RLC layer **215** of an eNodeB **110** and in UE **105**, respectively, according to an embodiment of the invention.

5 It should be noted that the term 'protocol entity' or more generally the term 'entity' is herein intended to comprise, but not limited to hardware, firmware, a combination of hardware and software, software.

For example, an protocol entity may be, but is not limited to being, a process running on a processor, a processor, an object, an executable, a thread of execution, a program, and/or a computing device (e.g., the UE **105**, the eNB **110**, as well as other radio network elements).

10 In other words, an entity may comprise an application being executed on a computing device and/or the computing device itself.

One or more entities may be localized on one computing device and/or distributed between two or more computing devices.

Entities may comprise and/or interact with computer readable media having storing data according to various data structures.

The entities may communicate by exploiting local and/or remote processes, preferably by means of electrical, electromagnetic and/or optical signals providing one or more data packets, such as data packets from one entity interacting with another entity in a local system, in a distributed system, and/or across a radio network and/or a wired network.

20 The eNB **110** comprises one or more further processing entities arranged at the RLC layer **215** for buffering and/or processing (e.g., segmenting, concatenating, ciphering and/or deciphering) data packets received from adjacent layers.

According to an embodiment of the present invention, the eNB **110** comprises one or more RLC relay entities **305** (as shown in **Figure 3A**) at the RLC layer **215**, along with RLC TX entities **310** and RLC RX entities **315** (the latter being known in the art and not herein further described for the sake of brevity).

The RLC relay entities **305** are arranged for acting as relays (i.e., for forwarder) of tunneled RLC PDUs as described in the following. The RLC relay entities **305** provide for tunneling of the RLC PDUs received from the transmitter UE **105tx** in corresponding tunneling RLC PDU and for forwarding such tunneling RLC PDU to the receiver UE **105rx** (as described in the following).

30 Similarly, the UE **105** – i.e., both the transmitter UE **105tx** and the receiver **105rx** since their role may (and usually do) switch during a communication (i.e., the receiver UE **105rx** may transmit data to the transmitter UE **105tx**) – in order to correctly process the tunneling PDUs comprise one or more further receiving entities, i.e. tunnel RLC RX entities **320**, provided at the RLC layer **215** along with RLC TX entities **310** and RLC RX entities **315**.

The tunnel RLC RX entities **320** are arranged for receiving the tunneling PDUs extracting the corresponding RLC PDUs transmitted by the transmitter UE **105tx** and deliver the latter to respective RLC RX entities **315** (as described in the following).

5 In an embodiment of the invention, the tunnel RLC RX entities **320** have substantially the same structure and capabilities of a RLC RX entities **315**, but the tunnel RLC RX entities **320** are arranged for providing their output to at least one RLC RX entities **315** within the RLC layer **215**.

During a communication, in the transmitter UE **105tx**, when from the MAC layer **220** a transmission allowance is provided to the RLC layer **215** (e.g. UE **105tx** received a grant from the eNB **110**), a RLC TX entity **310** delivers a RLC PDU to the MAC layer **220**.

10 Preferably, a size of the RLC PDU is decided based on a Channel Quality Indication, or CQI, assessed by the transmitter UE **105tx** on the sidelink **120** in case of a DM connection, or at the eNB **110** for the UL leg **115ul** in case of an IM connection. It should be noted that the PDU size assessment is transparent to the RLC TX entity **310**, which only has to send a RLC PDU of the requested size, performing segmentation and/or concatenation if necessary.

15 At the MAC layer a corresponding MAC PDU is generated to be sent (through the physical layer **225**) either to the receiver UE **105rx** or to the eNB **110**, according to whether a DM connection or an IM connection, respectively, is established. Particularly, the MAC PDU substantially comprises at least a portion of a RLC PDU received from the RLC layer **215** (as described in the following).

20 According to an embodiment of the present invention, one or more values of a header of the MAC PDU, a portion of which is shown on **Figure 4** and therein denoted by reference **400**, may be exploited for requesting to implement a tunneling of the payload of the MAC PDU (i.e., the RLC PDU).

In detail, the MAC header **400** comprises a Logical RLC connection ID, or LCID, value **405** (e.g. generally comprising 5 bits) which identifies the MAC PDUs comprised in a respective data flow (i.e., data comprised in a predetermined communication, e.g., such as a voice call, a file transfer, a streaming *etc.*).

25 During operation, respective RLC relay entities **305**, RLC TX entities **310**, RLC RX entity **315** and tunnel RLC RX entities **320** (at the transmitter UE **105tx**, at the eNB **110** and/or at the receiver UE **105rx**) are arranged for processing RLC PDUs having a predetermined LCID value **405**.

According to an embodiment of the present embodiment, in order to distinguish between MAC PDUs for IM and DM connections in a same data flow the LCID value **405** may be exploited.

30 In other words, the eNB **110** may be arranged for identifying whether a (portion of) RLC PDU comprised in a received MAC PDU is to be provided to a RLC relay entities **305** or to a RLC RX entity **315** based on the LCID value **405** of the MAC PDU.

For example, for distinguishing between IM connections and DM connection belonging to a same data flow a similar LCID value **405** as that used for DM connection, but with the Most Significant Bit, or MSB, is set

(equal to one) may be used for identifying a corresponding IM connection (e.g., in case of DM to IM mode switch, in the opposite case the MSB is reset to zero).

Alternatively, two LCID value **405** ranges may be defined for distinguishing between DM and IM connections. For example, LCID values **405** comprised in the range 01011-11011 may be assigned for IM connections, while the other LCID values **405** comprised in the range 00001-01010 may be assigned for DM connections. In this case, during a DM to IM mode switch the LCID values **405** for the IM connection may be simply obtained by adding the binary number 01010 to the LCID values **405** the corresponding DM connection (while in a mode switch from IM connection to DM connection the binary number 01010 is subtracted to the LCID values **405**).

In other words, the the eNB **110** may be arranged for identifying specific bit patterns in the LCID value **405** of the received MAC PDUs and, accordingly, providing the (portion of) RLC PDUs comprised in such MAC PDUs to a RLC relay entities **305** or to a RLC RX entity **315**.

As a further alternative, at least one of the reserved values **410ra** and **410rb** of the header of MAC PDUs may be exploited for distinguishing between DM connections and IM connections (thus allowing a larger number, i.e. double, of data flows to be addressed by means of the LCID values with respect to the previous embodiments).

Preferably, one reserved value **410ra**, hereinafter denoted as tunneling or TUN value **410ra**, may be exploited for denoting that the MAC PDU comprises a payload (i.e., a RLC PDU) to be tunneled in case of an IM connection.

For example, a TUN value **405ra** set to one denotes that the payload of the MAC PDU is to be tunneled (as described in the following).

For example, during a communication between UE **105tx** and **105rx**, when a DM connection is active, as shown in **Figures 5A** and **5B**, packet data exchange operates substantially as in a common D2D communication.

Each PDCP PDU received at the RLC layer **215** as a RLC SDU, such for example RLC SDU denote as **RLC SDU₁**, **RLC SDU₂** and **RLC SDU₃** in **Figure 5A**, is processed by a RLC TX entity **310** for generating one or more corresponding RLC PDUs, such as the **RLC PDU_{tx}** shown in **Figure 5A**.

For example, **RLC SDU₂** is segmented in two parts (only one of which shown in **Figure 5A**), one of which, preferably a first part **RLC SDU_{2-p1}**, is combined with the **RLC SDU₁** for forming a payload **505** of the corresponding **RLC PDU_{tx}**, which may be preferably ciphered with a RLC ciphering key.

Preferably, a (bit) size of the **RLC PDU_{tx}** is determined based on the CQI assessed by the transmitter UE **105tx** on the sidelink **120**.

The **RLC PDU_{tx}** further comprises a RLC header **510** which is combined with the payload **505**. The RLC header **510** comprises a sequence number **SN** identifying the **RLC PDU_{tx}**.

The **RLC PDU_{tx}** is passed to the MAC layer **220**, where it is considered as a MAC SDU, i.e. **MAC SDU_{tx}** shown in **Figure 5A**.

At the MAC layer **220**, the **MAC SDU_{tx}** forms a payload **515** of a corresponding MAC PDU, i.e. **MAC PDU_{tx}** of **Figure 5A**.

5 The **MAC PDU_{tx}** further comprises a MAC header **520** which is combined with the MAC payload **515**. The MAC header **520** comprises a LCID value **LCID** identifying the logical RLC connection, i.e. the sequence of RLC PDUs to which the MAC payload **515** (i.e., the **RLC PDU_{tx}**) belongs.

10 According to an embodiment of the invention, as shown in the non-limiting example of **Figure 5A**, one reserved bit **TUN** of the MAC header **520** is used for defining whether a data packet tunneling is requested or implemented. In case of DM connection, the tunneling is not requested and thus a value of the **TUN** bit is, e.g., set to zero (0; i.e., tunneling is not required).

Afterwards, the **MAC PDU_{tx}** is passed to the physical layer **225** where is processed and transmitted to the receiver UE **105rx** through the sidelink **120**.

15 At the receiver UE **105rx**, the **MAC PDU_{tx}** is received at the physical layer **225** and delivered to the MAC layer **220**.

The value of the **TUN** bit is checked, and being set to zero, the MAC payload **515**, i.e. the **MAC SDU_{tx}** or **RLC PDU_{tx}**, is extracted and passed to a RLC RX entity **315** associated with the LCID value **LCID** contained in the MAC header **520**, i.e. the RLC RX entity **315** arranged for managing received RLC PDUs of the sequence identified by the LCID value **LCID** (i.e., belonging to the same data flow).

20 At the RLC layer **215** as shown in **Figure 5B**, the **RLC PDU_{tx}** is buffered in the RLC RX entity **315** and then the RLC payload **505** (i.e., the **RLC SDU₁** and the **RLC SDU_{2-p1}**) is extracted.

The segmented RLC SDUs, such as the **RLC SDU₂** in the example of **Figures 5A** and **5B**, are reconstructed once subsequent on or more RLC PDUs (not shown) of the sequence (comprising the remaining segments of the respective RLC SDUs) are receive, and then delivered to the PDCP layer **210**.

25 It should be noted that the packet data are peered between transmitter UE **105tx** and the receiver UE **105rx**; therefore, RLC PDUs may be correctly reconstructed according to their sequence number **SN**.

30 Whenever a mode switching occurs from a DM connection to a IM connection (triggered whenever the CQI measured for an IM communication is assessed to be higher than the CQI of the established DM connection), the communication between the transmitter UE **105tx** and the receiver UE **105rx** proceeds in a substantially lossless manner as described in the following by making reference to **Figures 6A** to **6E**, which schematically shows a communication based on an IM connection according to an embodiment of the invention.

After a mode switch, at the transmitter UE **105tx** the operation proceeds substantially in the same manner as described above with respect to a DM connection.

35 Each PDCP PDU received at the RLC layer **215** of the transmitter UE **105tx** as a RLC SDU, such for example RLC SDUs denoted as **RLC SDU₄**, **RLC SDU₅** and **RLC SDU₆** in **Figure 6A**, is processed by a RLC

TX entity **310** for generating one or more corresponding RLC PDUs, such as the **RLC PDU_{tx}** shown in **Figure 6A**.

For example, **RLC SDU₅** is segmented in two parts (only one of which shown in **Figure 6A**), one of which, preferably a first part **RLC SDU_{5-p1}**, is combined with the **RLC SDU₄** for forming a payload **605** of the corresponding **RLC PDU_{tx}**, which may be preferably ciphered with a RLC ciphering key.

Preferably, a (bit) size of the **RLC PDU_{tx}** is determined based on the CQI assessed by the eNB **110** on the UL leg **115ul** of the IM connection.

The **RLC PDU_{tx}** further comprises a RLC header **610** which is combined with the payload **605**. The RLC header **610** comprises a sequence number **SN** identifying the **RLC PDU_{tx}**.

The **RLC PDU_{tx}** is passed to the MAC layer **220**, where it is considered as a MAC SDU, i.e. **MAC SDU_{tx}** shown in **Figure 6A**.

At the MAC layer **220**, the **MAC SDU_{tx}** forms a payload **615** of a corresponding MAC PDU, i.e. **MAC PDU_{tx}** of **Figure 6A**.

The **MAC PDU_{tx}** further comprises a MAC header **620** which is combined with the MAC payload **615**. The MAC header **620** comprises a LCID value **LCID** identifying the logical RLC connection, i.e. the sequence of RLC PDUs to which the MAC payload **615** (i.e., the **RLC PDU_{tx}**) belongs.

In the non-limiting example of **Figure 6A**, the **TUN** bit of the MAC header **520** is set to one (1; i.e., tunneling is required) since the communication is switched to an IM connection.

Afterwards, the **MAC PDU_{tx}** is passed to the physical layer **225** where is processed and transmitted to the eNB **110** through the UL leg **115ul** of the IM connection.

At the eNB **110** (as shown in **Figure 6B**), the **MAC PDU_{tx}** is received at the physical layer **225** and delivered to the MAC layer **220**. The value of the **TUN** bit is checked, and being set to one, the MAC payload **615**, i.e. the **MAC SDU_{tx}** or **RLC PDU_{tx}**, is extracted and passed to a RLC relay entity **305** of the RLC layer **215**.

It should be noted that in case a MAC PDU (transmitted by a UE, not shown) received at the eNB **110** has a **TUN** value **TUN** set to zero, such MAC PDU is processed according the known procedure used in IM connections.

The RLC relay entity **305** is associated with the LCID value **LCID** contained in the MAC header **620**, i.e. the RLC relay entity **305** is arranged for managing received RLC PDUs of the sequence identified by the LCID value **LCID** (i.e., belonging to the same data flow).

It should be noted that the packet data transmitted by the transmitter UE **105tx** through the UL leg **115ul** of the IM connection does not require to be peered with the eNB **110** in the embodiments according to the present invention, since they have not to be re-ordered and/or reconstructed (as described in the following).

At the RLC layer **215**, the **RLC PDU_{tx}** is buffered in the RLC relay entity **305**.

According to an embodiment of the invention, the **RLC PDU_{tx}** buffered in the RLC relay entity **305** is considered as a RLC SDU, e.g. a **RLC SDU_{eNB}** in the example of **Figure 6B** (instead of being transferred to the PDCP layer **210** as in the known solutions).

Thus, the **RLC SDU_{eNB}** (i.e., the **RLC PDU_{tx}**) is processed as a RLC SDU effectively received from the
 5 PDCP layer **210** of the protocol stack layer of the eNB **110**.

In other words, **RLC SDU_{eNB}** may be segmented in two or more parts (as shown in **Figure 6C**), one of which, preferably a first part **RLC SDU_{eNB-p1}** forms a payload **625** of the corresponding **RLC PDU_{eNB}**, which may be preferably ciphered with a RLC ciphering key.

Preferably, a (bit) size of the **RLC PDU_{eNB}** is determined based on the CQI assessed by the eNB **110**
 10 on the DL leg **115dl** of the IM connection.

The **RLC PDU_{eNB}** further comprises a RLC header **630** which is combined with the payload **625**. The RLC header **630** comprises a sequence number **SN_{eNB}** that identify and allows ordering the **RLC PDU_{eNB}** within a sequence of RLC PDUs to which belongs.

The **RLC PDU_{eNB}** is passed to the MAC layer **220**, where it is considered as a MAC SDU, i.e. **MAC SDU_{eNB}** shown in **Figure 6C**.
 15

At the MAC layer **220**, the **MAC SDU_{eNB}** forms a payload **635** of a corresponding MAC PDU, i.e. **MAC PDU_{eNB}** of **Figure 6C**.

The **MAC PDU_{eNB}** further comprises a MAC header **640** which is combined with the MAC payload **635**. The MAC header **640** comprises the LCID value **LCID** identifying the logical RLC connection, i.e. the sequence
 20 of RLC PDUs to which the MAC payload **635** (i.e., the **RLC PDU_{eNB}**) belongs.

In the non-limiting example of **Figure 6C**, the **TUN** bit of the MAC header **520** is set to one (1; i.e., tunneling is implemented).

Afterwards, the **MAC PDU_{eNB}** is passed to the physical layer **225** where is processed and transmitted to the receiver UE **105rx** through the DL leg **115dl** of the IM connection.

At the receiver UE **105rx**, the **MAC PDU_{eNB}** is received at the physical layer **225** and delivered to the
 25 MAC layer **220**. The value of the **TUN** bit is checked, and being set to one, the MAC payload **635**, i.e. the **MAC SDU_{eNB}** or **RLC PDU_{eNB}**, is extracted and passed to a tunnel RLC RX entity **320** associated with the LCID value **LCID** contained in the MAC header **640** (as shown in **Figure 6D**), i.e. the tunnel RLC RX entity **320** arranged for managing received RLC PDUs of the sequence identified by the same LCID value **LCID**.

At the tunnel RLC RX entity **320** in the RLC layer **215**, the **MAC SDU_{eNB}** (i.e., **MAC PDU_{eNB}**), which
 30 comprises the first part **RLC SDU_{eNB-p1}** of the **RLC SDU_{eNB}**, is buffered until one or more next **MAC SDU_{eNB-nx}** (i.e., **RLC PDU_{eNB-nx}**, only one shown in the example shown in **Figure 6E**) comprising the remaining parts of the **RLC SDU_{eNB}**, are received at the tunnel RLC RX entity **320**.

It should be noted that the packet data transmitted through the DL leg **115dl** of the IM connection by the
 35 eNB **110** are peered with the receiver UE **105rx**; therefore, RLC PDUs generated by the eNB **110**, such as the

RLC PDU_{eNB}, may be correctly reconstructed according to their sequence number SN_{eNB} at the tunnel RLC RX entity **320** of the receiver UE **105rx**.

5 Afterwards, the payloads **625** (i.e., the RLC SDU_{eNB-p1} and the RLC SDU_{eNB-p2}) of the MAC SDU_{eNB} and of the MAC SDU_{eNB_nx} are combined (at the tunnel RLC RX entity **320**) in order to reconstruct the RLC SDU_{eNB}, i.e. the RLC PDU_{tx} originally transmitted by the transmitter UE **105tx**.

Particularly, the packet data generated by the eNB **110** are peered with the tunnel RLC RX entity **320** at the receiver UE **105rx**; therefore, RLC PDUs may be correctly ordered according to their sequence number SN_{eNB} and the RLC SDU_{eNB} may be correctly reconstructed.

10 After being reconstructed, the payload **605** of the RLC PDU_{tx} is buffered in a RLC RX entity **315** arranged for managing received RLC PDUs of the sequence identified by the same LCID value **LCID**.

At the RLC layer **215**, the RLC PDU_{tx} is buffered in the RLC RX entity **315** and then the RLC payload **605** (i.e., the RLC SDU₄ and the RLC SDU_{5-p1}) is extracted, the segmented RLC SDUs, such as the RLC SDU₅ in the example of **Figure 6E**, are reconstructed once subsequent RLC PDUs (not shown) of the sequence are receive, and delivered to the PDCP layer **210**.

15 It should be noted that the packet data generated by the transmitter UE **105tx** are still peered with the RLC RX entity **315** at the receiver UE **105rx**; therefore, RLC PDUs, such as the RLC PDU_{tx}, may be correctly ordered according to their sequence number **SN** and similarly the PDCP PDU (i.e., the RLC SDU) may be correctly reconstructed and then deciphered at the PDCP Layer **210**.

20 Advantageously, a mode switch from IM connection to DM connection simply implies that the **TUN** bit is simply reset to zero in the MAC header of MAC PDUs generated at the transmitter UE **105tx** after the mode switch; thus the communication proceeds seamlessly in DM connection as described above with respect to **Figures 5A** and **5B**.

Thanks to the tunneling implemented during mode switching according to the present invention, avoidance of losses and avoidance of duplicates during a mode switch are substantially ensured.

25 Indeed, all RLC PDUs are sent only once by the transmitter UE **105tx**, on either the sidelink **120** or UL leg **115ul**. All RLC PDUs sent by the transmitter UE **105tx** are then received by the same RLC RX entity **315** at the receiver UE **105rx**, i.e. the RLC RX entity **315** associated with the LCID value that identifies the data flow of the communication. Such RLC RX entity **315** performs reassembly and in-order delivery to the PDCP layer **210**.

30 The mode switch is thus fully transparent to any PDCP entities at the PDCP layer **210**.

Moreover, a reduction of the overhead at the eNB **110** is attained (i.e., in IM connection), since data packets have not to traverse the whole protocol stack at the eNB **110** but are forwarded to the receiver UE **105rx** after reaching the RLC layer **215**.

Thus data packets transmitted by the transmitter UE **105tx** do not require any reassembly of segments of the RLC SDUs (such as **RLC SDU_{5,p1}** in the example of **Figures 6A – 6E**) at the RLC layer **215** of the eNB **110** since they passed at higher protocol layers.

Particularly, PDCP PDU transmitted by the transmitter UE **105tx** are not processed at the PDCP layer **210** of the eNB **110**. This entails that, de-cyphering of PDCP PDUs received from the RLC layer **215**, transmission to higher layers (i.e., IP layer **205** and upper protocol layers) for further processing, receipt of data packets resulting from such further processing, cyphering of said received data packets and generation of corresponding PDCP PDUs to be sent to the receiver UE **105rx** are completely avoided.

Thus, a general reduction of the workload of the eNB **110**, while assisting switching D2D communications, is attained.

The mode switching according to an embodiment of the present invention allows for a reduction of latency. In facts, since according to the present invention the eNB **110** does not perform reassembly on data packets at RLC layer **210** and does not forward the IP data packets extracted from the PDCP SDU to the core network (i.e. that manages the operation at higher protocol stack layers above the IP layer **205**) before generating corresponding data packets to be sent to the receiver UE **105rx**, the relaying of data packets received from the transmitter UE **105tx** to the receiver UE **105rx** is faster.

In alternative embodiment of the invention, instead of implementing a further RLC PDU at the RLC layer **210** of the eNB **110**, part of the retransmission mechanism of the Acknowledged Mode, or AM, at the RLC layer **210** is exploited. The retransmission mechanism of the AM is thoroughly described in 3GPP - TS 36.322 v12.2.0, “Evolved Universal Terrestrial Radio Access (E-UTRA); Radio Link Control (RLC) protocol specification”, March 2015 and is not herein reported for the sake of brevity.

According to an embodiment of the present invention, the eNB **110** is arranged to manage the transmission buffer included in the RLC Relay entity **305** as a retransmission buffer.

When a MAC PDU (e.g., such as the **MAC PDU_{tx}** of the exemplary embodiment described with reference to **Figures 6A-6E**) having a TUN value **TUN** set to one is received at the eNB **110** from the transmitter UE **105tx** the corresponding RLC PDU (contained in the payload of the MAC PDU) is queued into a RLC Relay entity **305** (as in the exemplary embodiment described with reference to **Figures 6A-6E**).

In this case, the RLC PDU is not considered as a new RLC SDU to be tunneled into another RLC PDU, as described above. Instead, the RLC PDU, such as the **RLC PDU_{tx}**, is tunneled by being re-segmented according to the retransmission mechanism used in an AM RLC entity (not shown).

In case of using the RLC AM, the RLC PDUs sent by the transmitter UE **105tx** received at the eNB **110** may be tunneled into one or more RLC AM PDUs, such as the **AM PDU** of **Figure 7**, to be sent to the receiver UE **105rx**.

It should be noted that RLC PDUs sent by the transmitter UE **105tx** received at the eNB **110** may also be segmented in two or more RLC AM PDUs, so as to adapt to possibly different MAC PDU size due to different CQIs of the UL leg **115ul** and the DL leg **115dl** of the IM connection.

In such case, at least a segment of the payload (i.e., the RLC SDU) of the original RLC PDU (such as the payload **605**, the **RLC SDU_{tx}**, of the **RLC PDU_{tx}** of the exemplary embodiment described with reference to **Figures 6A-6E**) may be mapped into a payload **705** of the **AM PDU**.

Moreover, a header **710** of the **AM PDU** may be set as described hereinbelow in order to allow the receiver UE **105rx** correctly extracting the segment of the payload of the RLC PDU tunneled into the **AM PDU**.

For example, a flag **RF** of the header **710** of the **AM PDU** may be set to one (1), so as to indicate that the **AM PDU** comprises a segment of the payload of the RLC PDU.

A sequence number value **SN_{AM}** of the header **710** of the **AM PDU** is set as the same sequence number value **SN** contained in the header of the original RLC PDU generated by the transmitter UE **105tx**.

A field **SO** of the header **710** of the **AM PDU** may be exploited for indicating a position (e.g., in bytes) of the segment of the payload of the **AM PDU** in the RLC SDU of which is part.

A field **LSF** of the header **710** of the **AM PDU** indicates whether the last byte of the segment of the payload of the RLC PDU corresponds to the last byte of the RLC PDU.

For example, if the eNB **110** receives a RLC PDU comprising 100 bytes from the transmitter UE **105tx**, the RLC PDU at the RLC Relay entity **305** may be segmented into two segments each with a size of 50 bytes. Each segment maintains the SN value **SN** of the original RLC PDU, whereas the field **SO** is set accordingly (e.g., the AM PDU comprising the first segment of the RLC PDU has a field SO set to a lower value than the value of the field SO of the AM PDU comprising the second segment of the RLC PDU).

At the receiver UE **105rx**, the RLC AM PDU can be sent to the RLC RX entity **315** that peers directly with the transmitter UE **105tx** (i.e., a LCID value **LCID** identifying the logical RLC connection used for DM transmission). This means that receiver UE **105rx** has to perform reassembly only once, since the SN value **SN** remain the same used in the UL leg **115ul** of the IM connection and, thanks to the use of field **SO**, there is enough information for performing a reassembly of the two segments of the RLC PDU.

It should be noted that AM RLC does not allow concatenating segments of two different PDUs, since only one SN value **SN** may be specified in the header **710** of the **AM PDU**. Such limitation that may lead to an overall reduction in the system throughput with respect to the previous embodiment.

The Applicant has further performed simulations that highlight the benefits of the described solutions.

The Applicant has found that the mode switching according to the embodiments of the present invention allows for an improvement of cell throughput.

Indeed, reduction in latency implies a throughput improvement particularly (although not limitatively) for data flows using TCP.

As known, TCP data flows (due to the nature of the TCP protocol itself) are susceptible to losses and duplicates, which may cause degradation of the TCP congestion window and consequently reduce the sending rate.

5 The tunneling implemented in the mode switch according to the embodiments of the present invention avoids both losses and duplicates during a mode switching.

In detail, a radio network arrangement comprising a pair of D2D-capable UE, performing a file transfer using TCP has been considered (such as the radio network arrangement shown in **Figures 1A** and **1B**).

10 During the TCP file transfer the UE cyclically moved (e.g., at a speed substantially equal to 3 m/s) towards each other and in opposite directions, so as to allow periodic mode switching (e.g., triggered whenever the CQI measured of the current IM or DM connection became lower than the CQI of the other connection mode).

Figure 8 shows the evolution of the TCP congestion window (measured in KB) over time (measured in seconds).

15 In **Figure 8**, crosses and circles indicate time instants at which a mode switch is triggered; particularly, crosses indicate DM connection to IM connection mode switches, while circles indicate IM connection to DM connection mode switches.

The solid line **805** refers to a radio network arrangement of the known art, i.e. in which the solution according to the present invention is not implemented (used as a baseline for comparison). In this case, at mode switch all buffered data packets are dropped and no attempt to recover them (in the LTE stack) is made, which is a behavior of known 3GPP-compliant UE during a mode switch.

20 Such data packets drop lead to a reduction (substantially a reset) of the TCP congestion window at every mode switch, as can be clearly appreciated from **Figure 8**.

Conversely, the dashed line **810** refers to a radio network arrangement according to the embodiments of the present invention.

25 As can be appreciated from **Figure 8**, the radio network arrangement according to the embodiments substantially completely avoids window reductions and provides a substantially linear growth of the TCP congestion window over time (i.e., the dashed line **810** shows a substantially linear increase over time).

Figure 9 is a bar chart showing application layer throughputs associated with the considered TCP file transfer.

30 Particularly, different radio network arrangements, each implementing a respective TCP congestion control algorithm known in the art, have been tested and compared (in terms of application layer throughput) with a radio network arrangement according to the present invention.

In detail, bin **905** refers to a radio network arrangement implementing Tahoe algorithm, bin **910** refers to a network arrangement implementing Reno algorithm, bin **915** refers to a radio network arrangement implementing New Reno algorithm, bin **920** refers to a radio network arrangement implementing Westwood algorithm, and bin **925** refers to a radio network arrangement implementing Reno with Selective

Acknowledgements algorithm, while bins **930** refers to a radio network arrangement according to the present invention.

The Applicant observed that the application layer throughput is always substantially higher in the radio network arrangement according to the present invention with respect to radio network arrangements implementing known TCP congestion control algorithms, only the “Reno with Selective Acknowledgements” algorithm shows performance comparable with the solution according to embodiments of the present invention.

CLAIMS

1. A method for managing data packets (**MAC PDU_{tx}**, **RLC PDU_{tx}**) transmitted by a first user equipment (**105_{tx}**) to be received by a second user equipment (**105_{rx}**) through a radio network, the method comprising
5 having the radio network comprising a radio transceiver station (**110**) configured for:
receiving data packets (**MAC PDU_{tx}**; **RLC PDU_{tx}**) transmitted by the first user equipment;
for each data packet, checking whether the data packet comprises a request for a data packet tunneling (**TUN, LCID**);
for each data packet comprising a request for data packet tunneling, providing the data packet
10 to a relay protocol entity (**305**) at a Radio Link Control protocol layer (**215**), the relay protocol entity being configured for:
generating at least one tunneling data packet (**RLC PDU_{eNB}**; **AM PDU**), said generating at least one tunneling data packet comprises inserting at least a portion (**625**) of the transmitted data packet into the at least one tunneling data packet, and
15 transmitting the tunneling data packet to the second user equipment.
2. The method according to claim 1, wherein receiving data packets (**MAC PDU_{tx}**; **RLC PDU_{tx}**) transmitted by the first user equipment comprises:
receiving Medium Access Control data packets (**MAC PDU_{tx}**) at a Medium Access Control protocol layer
20 (**220**), each Medium Access Control data packet comprising a header portion (**620**) and a payload portion (**615**),
and
wherein checking whether the data packet comprises a request for a data packet tunneling (**TUN, LCID**) comprises:
checking whether the header of each Medium Access Control data packet comprises the request for a
25 data packet tunneling (**TUN, LCID**).
3. The method according to claim 2, wherein checking whether the header of each Medium Access Control data packet comprises a request for a data packet tunneling comprises:
checking a value (**TUN**) of a predetermined reserved bit comprised in the header of the Medium Access
30 Control data packet.
4. The method according to claim 2, wherein checking whether the header of each Medium Access Control data packet comprises a request for a data packet tunneling comprises:
checking a value (**LCID**) of a predetermined sequence of bits comprised in the header of the Medium
35 Access Control data packet.

5. The method according to any one of the preceding claims 2 to 4, wherein the payload of the Medium Access Control data packet comprises at least a portion of a Radio Link Control data packet (**RLC PDU_{tx}**), and wherein generating at least one tunneling data packet (**RLC PDU_{eNB}**) comprises:

5 generating at least one Radio Link Control tunneling data packet (**RLC PDU_{eNB}**) at the Radio Link Control protocol layer, said generating at least one Radio Link Control tunneling data packet comprises inserting at least a portion (**625**) of the Radio Link Control data packet (**RLC PDU_{tx}**) into the at least one Radio Link Control tunneling data packet.

10 6. The method according to claim 5, wherein the Radio Link Control tunneling data packet (**RLC PDU_{eNB}**) comprises a tunneling header portion (**630**) and a tunneling payload portion (**625**), and wherein generating at least one Radio Link Control tunneling data packet comprises inserting the at least a portion of the Radio Link Control data packet in the payload of the at least one Radio Link Control tunneling data packet.

15 7. The method according to claim 6, wherein the Radio Link Control data packet (**RLC PDU_{tx}**) comprises a header portion (**610**) and a payload portion (**605**), and wherein the header portion of the Radio Link Control data packet comprises an indication (**SN**) of a position in a sequence of Radio Link Control data packets thereof, and
20 the tunneling header portion of the Radio Link Control tunneling data packet comprises an indication (**SN_{eNB}**) of a tunneling position in a sequence of Radio Link Control tunneling data packets thereof, and wherein the indication of a position is different from the indication of a tunneling position.

25 8. The method according to any one of the previous claim 5 to 7, wherein transmitting the tunneling data packet to the second user equipment comprises:
 generating a Medium Access Control data packet (**MAC PDU_{eNB}**), the Medium Access Control data packet (**MAC PDU_{eNB}**) comprising a header portion (**640**) and a payload portion (**635**), the header of the Medium Access Control data packet comprises an indication (**TUN, LCID**) that a tunneling of data packets has been implemented, and the payload of the Medium Access Control data packet comprises the at least one Radio Link
30 Control tunneling data packet (**RLC PDU_{eNB}**), and
 transmitting the Medium Access Control data packet to the second user equipment.

9. The method according to claim 1, wherein generating at least one tunneling data packet (**AM PDU**), comprises:

generating at least one tunneling data packet as at least one Acknowledge Mode data packet (**AM PDU**),
 and
 inserting at least a portion of the transmitted data packet into the at least one Acknowledge Mode data
 packet.

5

10. The method according to claim 9, wherein the transmitted data packet comprises a Radio Link
 Control data packet (**RLC PDU_{tx}**), the Radio Link Control data packet comprising an indication (**SN**) of a position
 in a sequence of Radio Link Control data packets thereof, and

10

wherein generating at least one tunneling data packet as at least one Acknowledge Mode data packet
 comprises

setting an indication (**SN_{AM}**) of a position in a sequence of Acknowledge Mode data packets of the
 Acknowledge Mode data packet equal to the indication (**SN**) of a position in a sequence of Radio Link Control
 data packets comprised in the Radio Link Control data packet.

15

11. The method according to claim 10, wherein inserting at least a portion of the transmitted data packet
 into the at least one Acknowledge Mode data packet comprises:

segmenting the Radio Link Control data packet in two or more segments;

for each segment of the Radio Link Control data packet:

20

inserting the segment of the Radio Link Control data packet in a respective Acknowledge Mode
 data packet, and

providing in the Acknowledge Mode data packet an indication (**SO**) of a position of the segment
 of the Radio Link Control data packet in the Radio Link Control data packet of which is part.

25

12. A method for managing data packets (**MAC PDU_{tx}**, **RLC PDU_{tx}**) transmitted by a first user equipment
 (**105_{tx}**) to be received by a second user equipment (**105_{rx}**), the method comprising having the second user
 equipment (**105_{rx}**) configured for:

receiving data packets (**MAC PDU_{tx}**; **RLC PDU_{tx}**; **MAC PDU_{eNB}**; **RLC PDU_{eNB}**; **AM PDU**) transmitted by
 the first user equipment or by a radio transceiver station (**110**) of a radio network;

30

for each data packet, checking whether the data packet (**RLC PDU_{eNB}**) comprises an indication of the
 implementation of a data packet tunneling (**TUN**, **LCID**);

for each data packet comprising an indication of the data packet tunneling, providing the data
 packet to a tunneling receiver protocol entity (**320**) at a Radio Link Control protocol layer (**215**), the
 tunneling receiver protocol entity (**320**) being configured for:

35

extracting at least a portion of a tunneled data packet (**RLC PDU_{tx}**) from said data
 packet, and

providing the at least a portion of a tunneled data packet (**RLC PDU_{tx}**) to a receiver protocol entity (**315**) at the Radio Link Control protocol layer.

13. The method according to claim 12, wherein receiving data packets (**MAC PDU_{tx}**; **RLC PDU_{tx}**; **MAC PDU_{eNB}**; **RLC PDU_{eNB}**) transmitted by the first user equipment or by a radio transceiver station (**110**) of a radio network comprises:

receiving Medium Access Control data packets (**MAC PDU_{tx}**; **MAC PDU_{eNB}**) at a Medium Access Control protocol layer (**220**), each Medium Access Control data packet comprising a header portion (**520**; **640**) and a payload portion (**515**; **635**), and

10 wherein checking whether the data packet comprises an indication of the data packet tunneling comprises:

checking whether the header of each Medium Access Control data packet comprises the indication of the data packet tunneling.

14. The method according to claim 13, wherein checking whether the header of each Medium Access Control data packet comprises a request for a data packet tunneling comprises:

checking a value (**TUN**) of a predetermined reserved bit comprised in the header of the Medium Access Control data packet.

15. The method according to claim 13, wherein checking whether the header of each Medium Access Control data packet comprises a request for a data packet tunneling comprises:

checking a value (**LCID**) of a predetermined sequence of bits comprised in the header of the Medium Access Control data packet.

16. The method according to any one of the preceding claims 13 to 15, wherein the payload portion (**635**) of the Medium Access Control data packets (**MAC PDU_{eNB}**) comprises a Radio Link Control tunneling data packet (**RLC PDU_{eNB}**), and

wherein extracting at least a portion of a tunneled data packet (**RLC PDU_{tx}**) from said data packet comprises:

30 extracting at least a portion of a Radio Link Control data packet (**RLC PDU_{tx}**) generated by the first user equipment from the Radio Link Control tunneling data packet (**RLC PDU_{eNB}**).

17. The method according to claim 16, wherein said Radio Link Control tunneling data packet (**RLC PDU_{eNB}**) comprises a header portion (**630**) and a payload portion (**625**), the at least a portion of a Radio Link Control data packet) generated by the first user equipment being comprised in said payload portion (**625**) of the

Radio Link Control tunneling data packet.

18. the method according to claim 17, wherein the header portion (**630**) of the Radio Link Control tunneling data packet (**RLC PDU_{eNB}**) comprises an indication (**SN_{eNB}**) of a position in a sequence of Radio Link Control tunneling data packets thereof, and

wherein providing the at least a portion of a tunneled data packet (**RLC PDU_{tx}**) to a receiver protocol entity (**315**) at the Radio Link Control protocol layer comprises:

reconstructing a Radio Link Control data packet by combining portions of the Radio Link Control data packet contained in the payload of Radio Link Control tunneling data packet comprising indications of adjacent positions in a sequence of Radio Link Control tunneling data packets.

19. A radio network comprising a radio transceiver station (**110**) arranged for managing data packets (**MAC PDU_{tx}**, **RLC PDU_{tx}**) transmitted by a first user equipment (**105_{tx}**) to be received by a second user equipment (**105_{rx}**), the radio transceiver station comprising hardware, firmware, a combination of hardware and software, or software configured for implementing the method according to any one of the preceding claims 1 to 11.

20. A user equipment (**105_{tx}**; **105_{rx}**) arranged for transmitting to and/or receiving from a further user equipment (**105_{rx}**; **105_{tx}**) data packets (**MAC PDU_{tx}**, **RLC PDU_{tx}**) by means of a Direct Mode connection in which data packets are directly transmitted to and/or received from the further user equipment or by means of an Infrastructure Mode connection in which data packets are transmitted to and/or received from the user equipment and the further user equipment through a radio transceiver station (**110**) of a radio network, the user equipment comprising hardware, firmware, a combination of hardware and software, or software configured for implementing the method according to any one of the preceding claims 12 to 17.

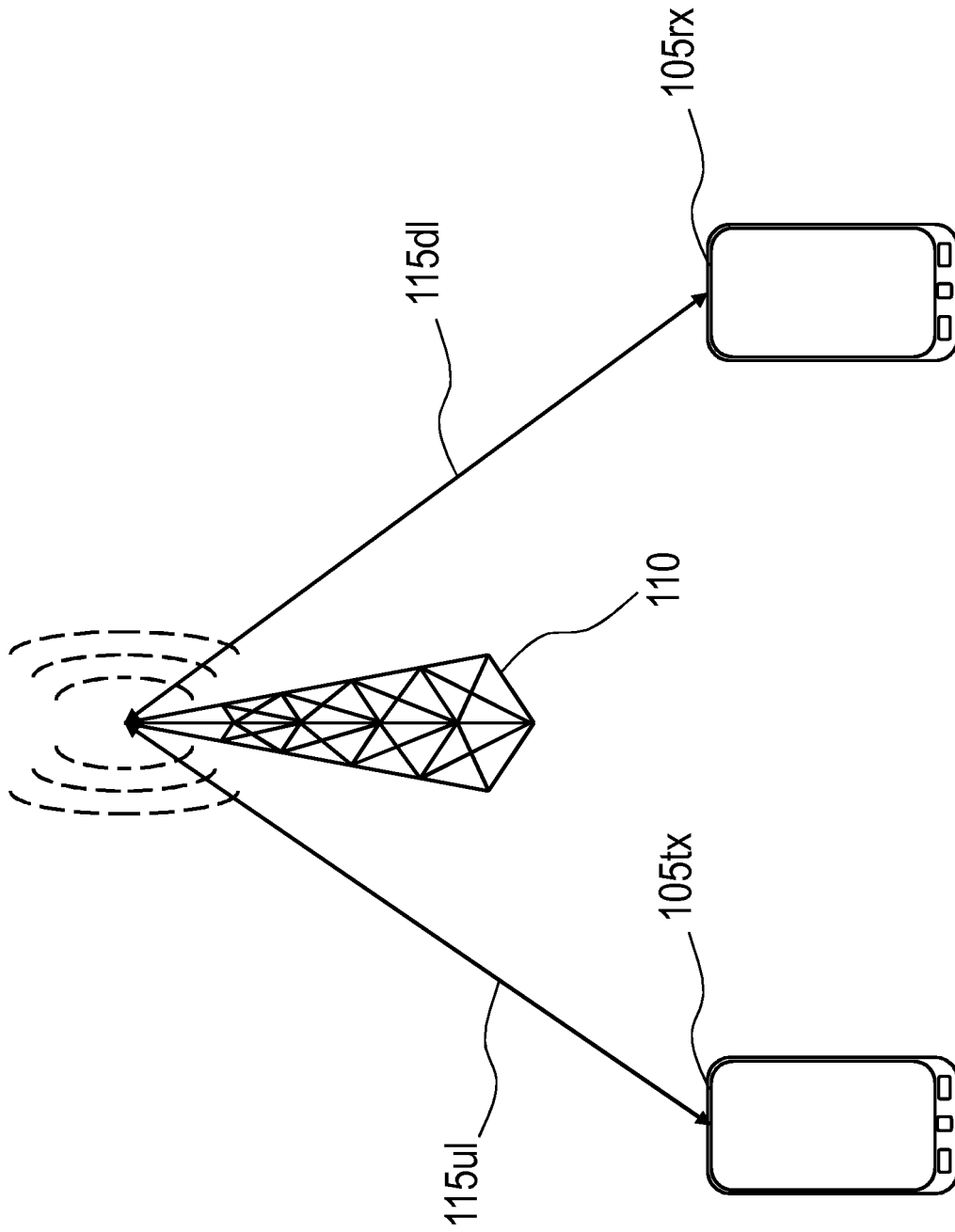

FIG.1A

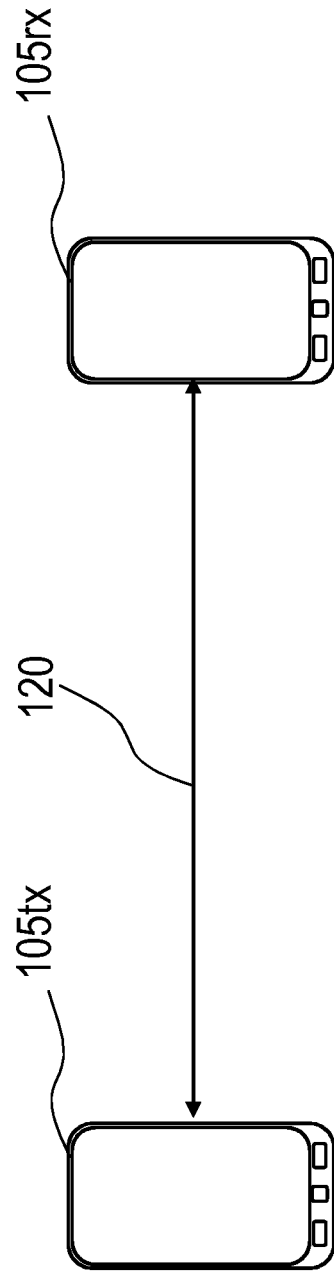
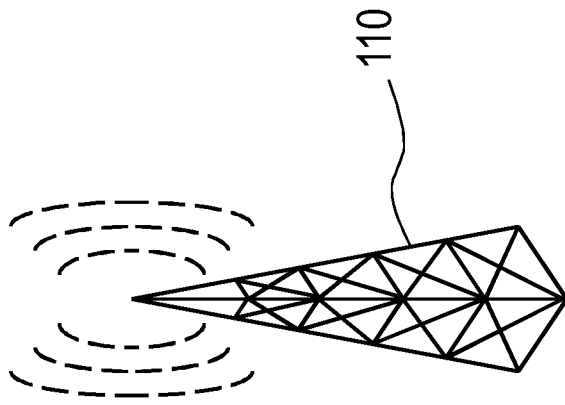

FIG.1B

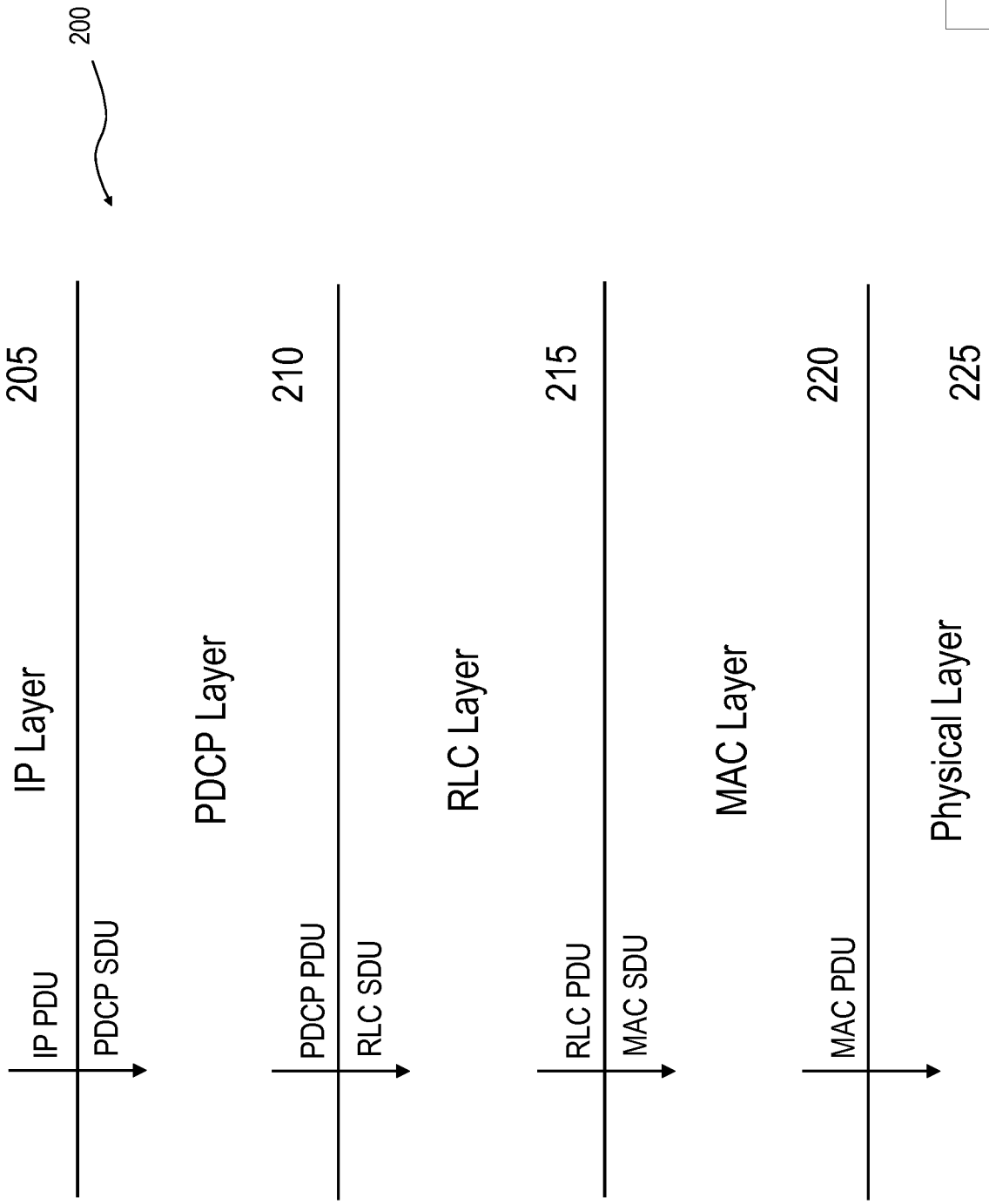

FIG.2

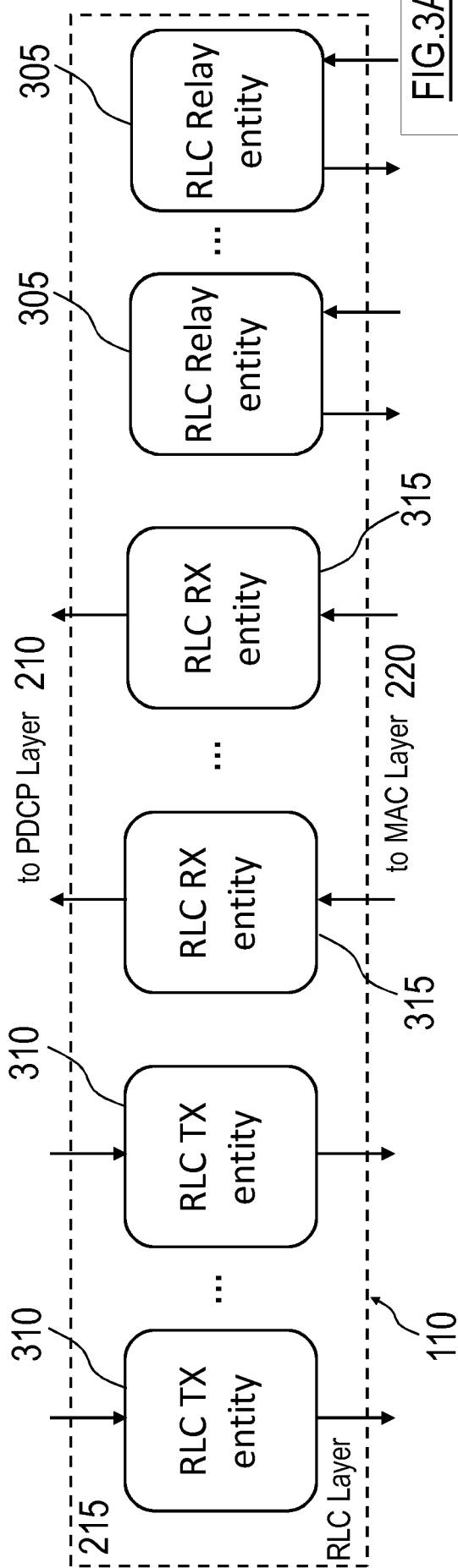

FIG. 3A

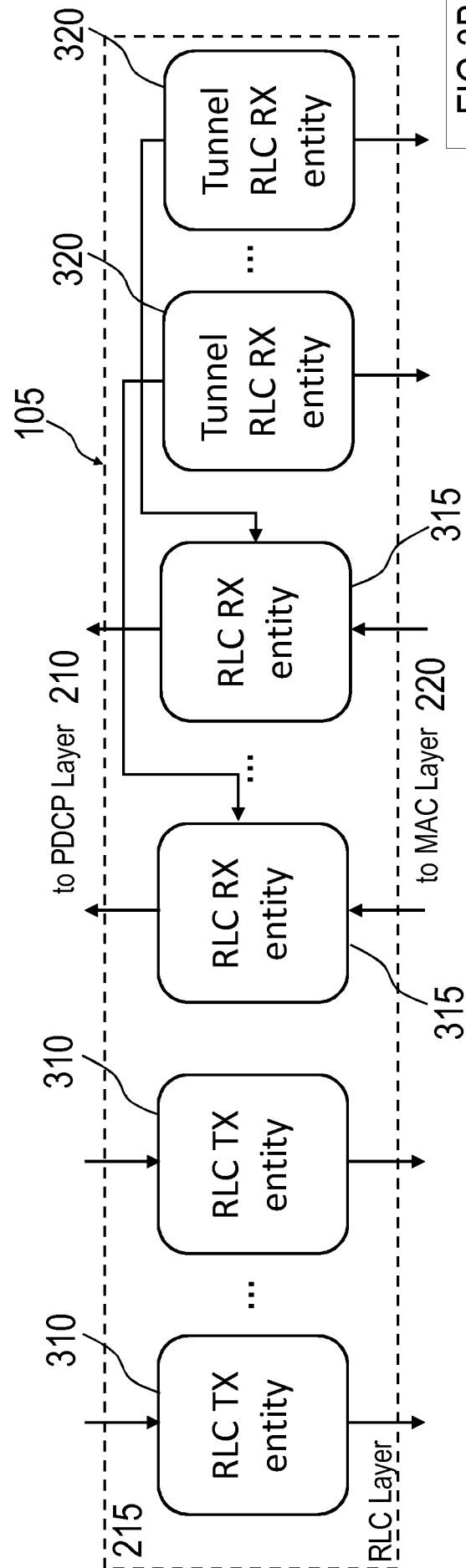
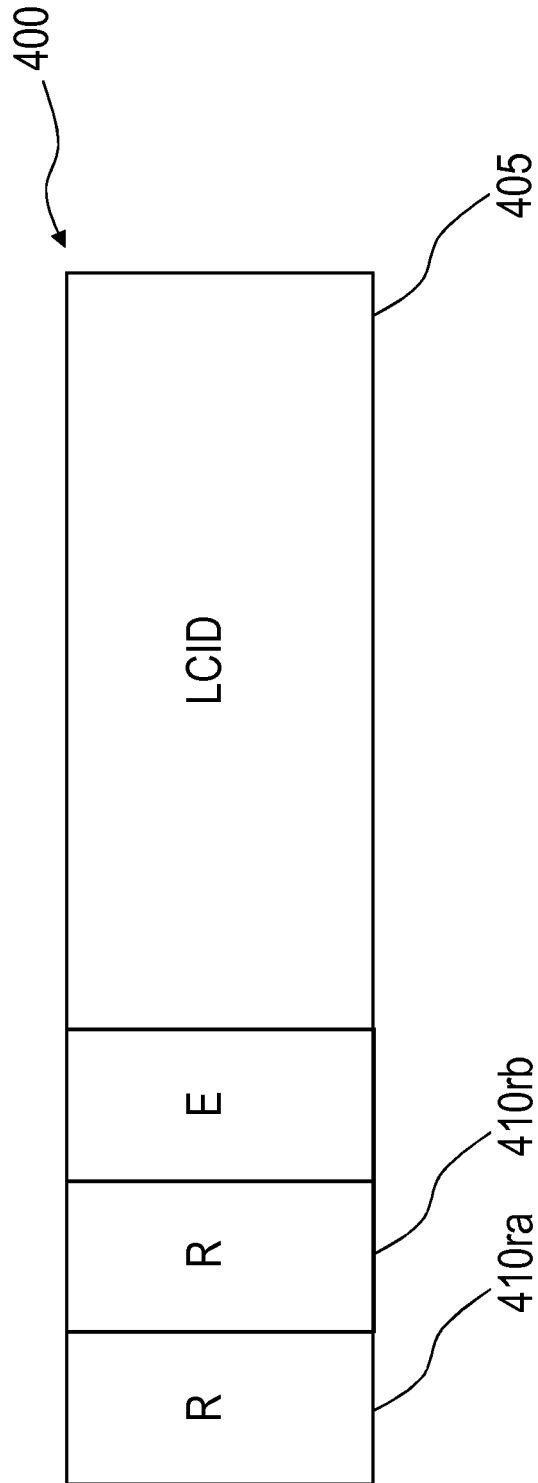

FIG. 3B

FIG.4



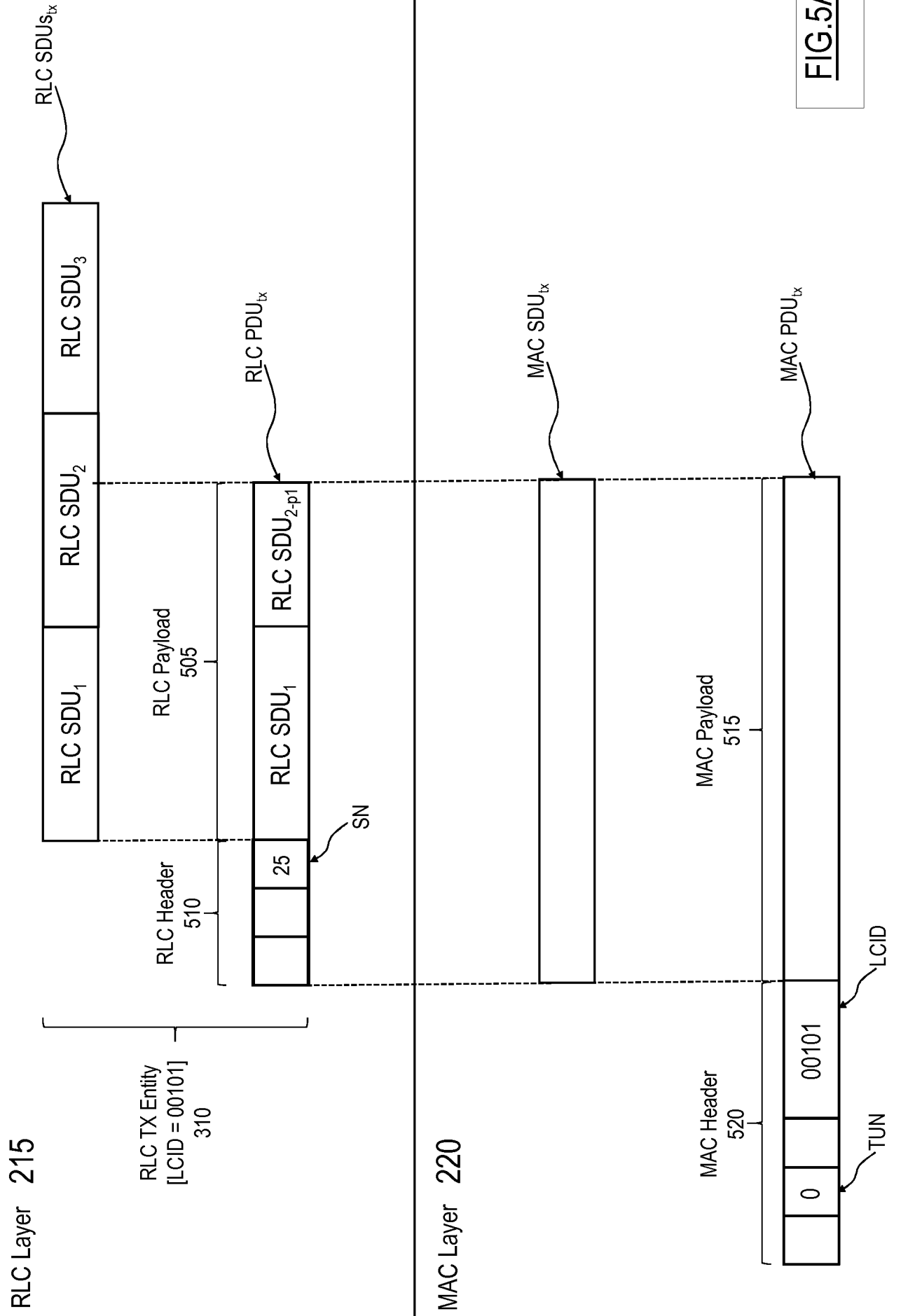

FIG.5A

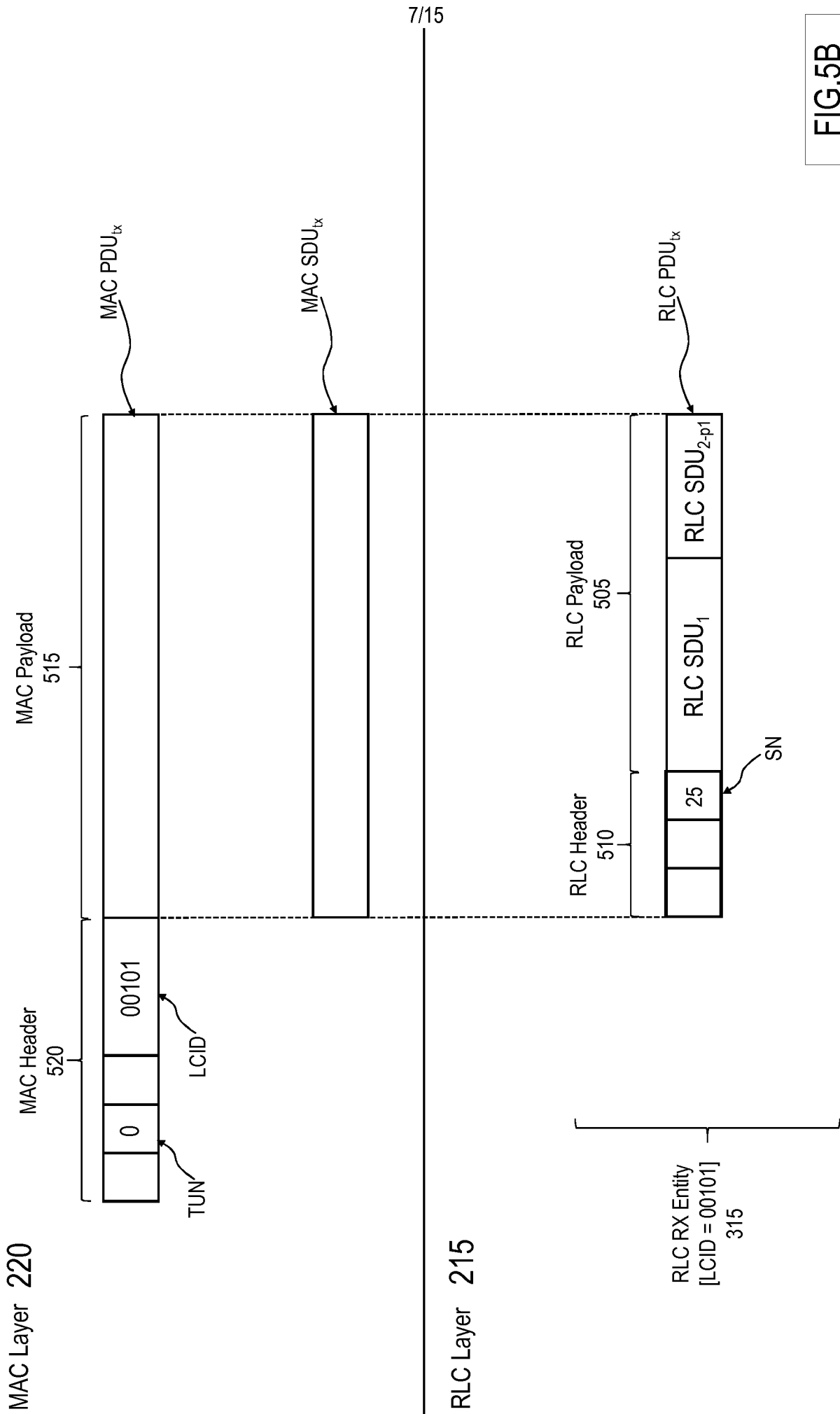

FIG.5B

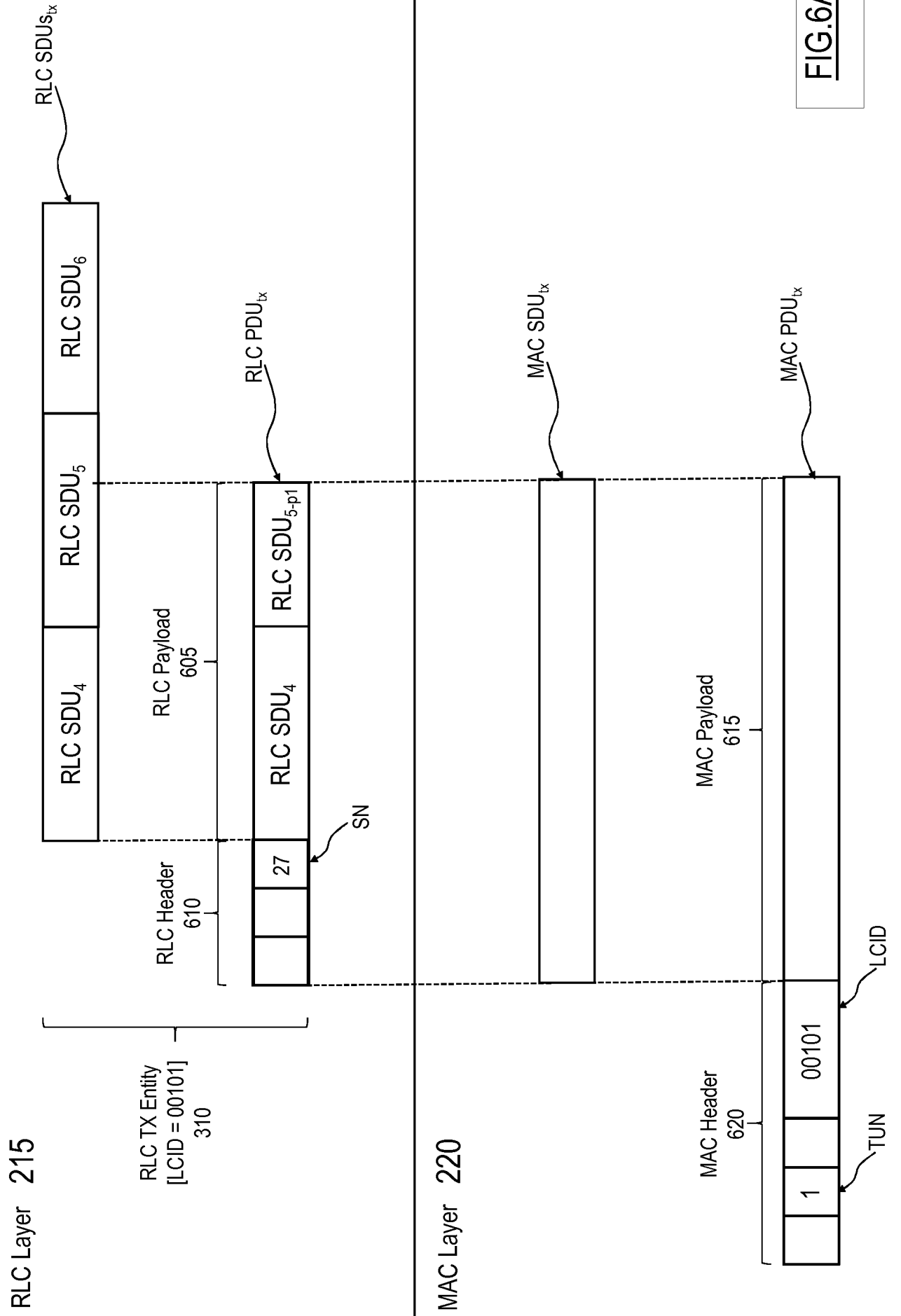

FIG.6A

MAC Layer 220

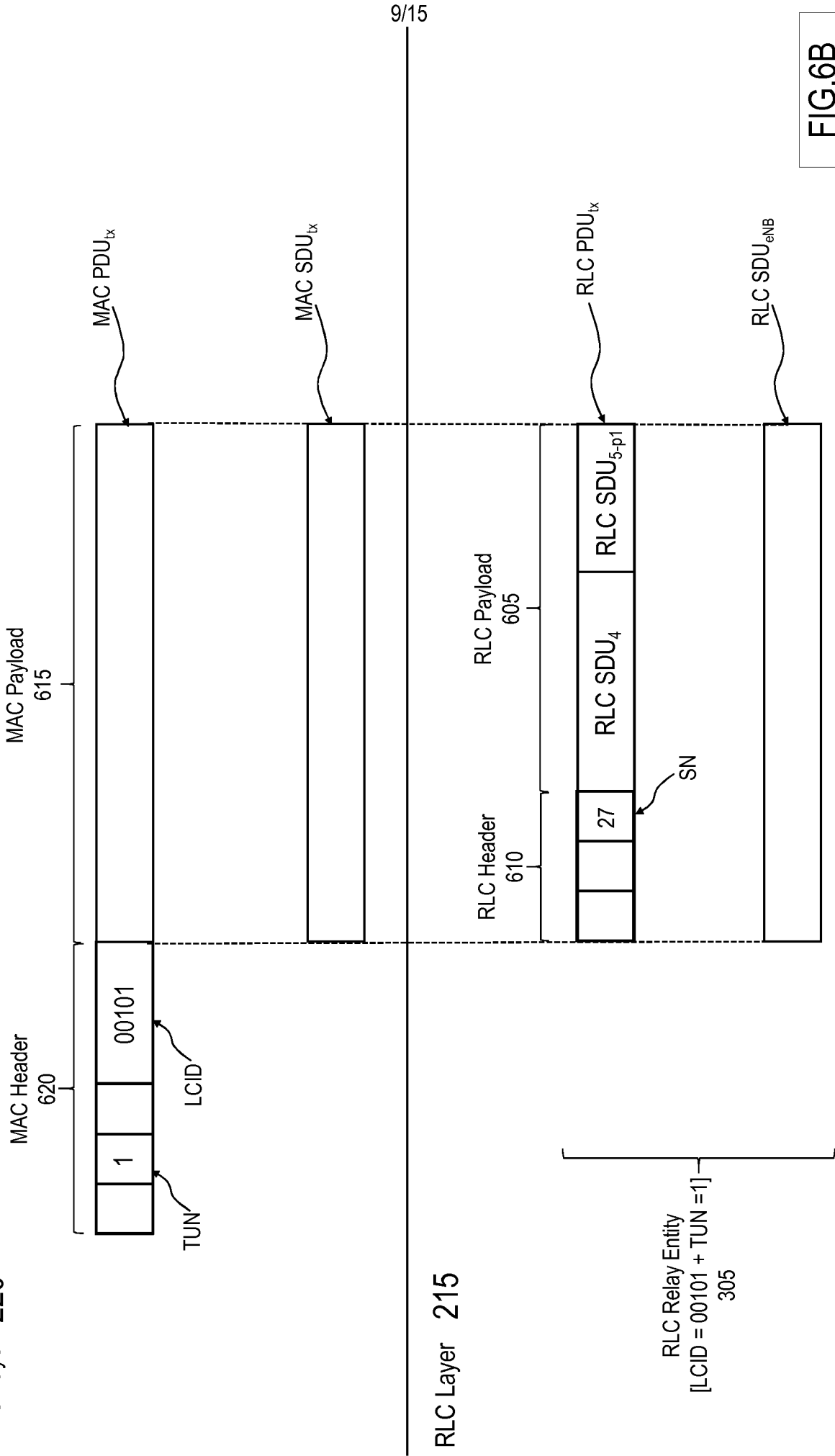

FIG.6B

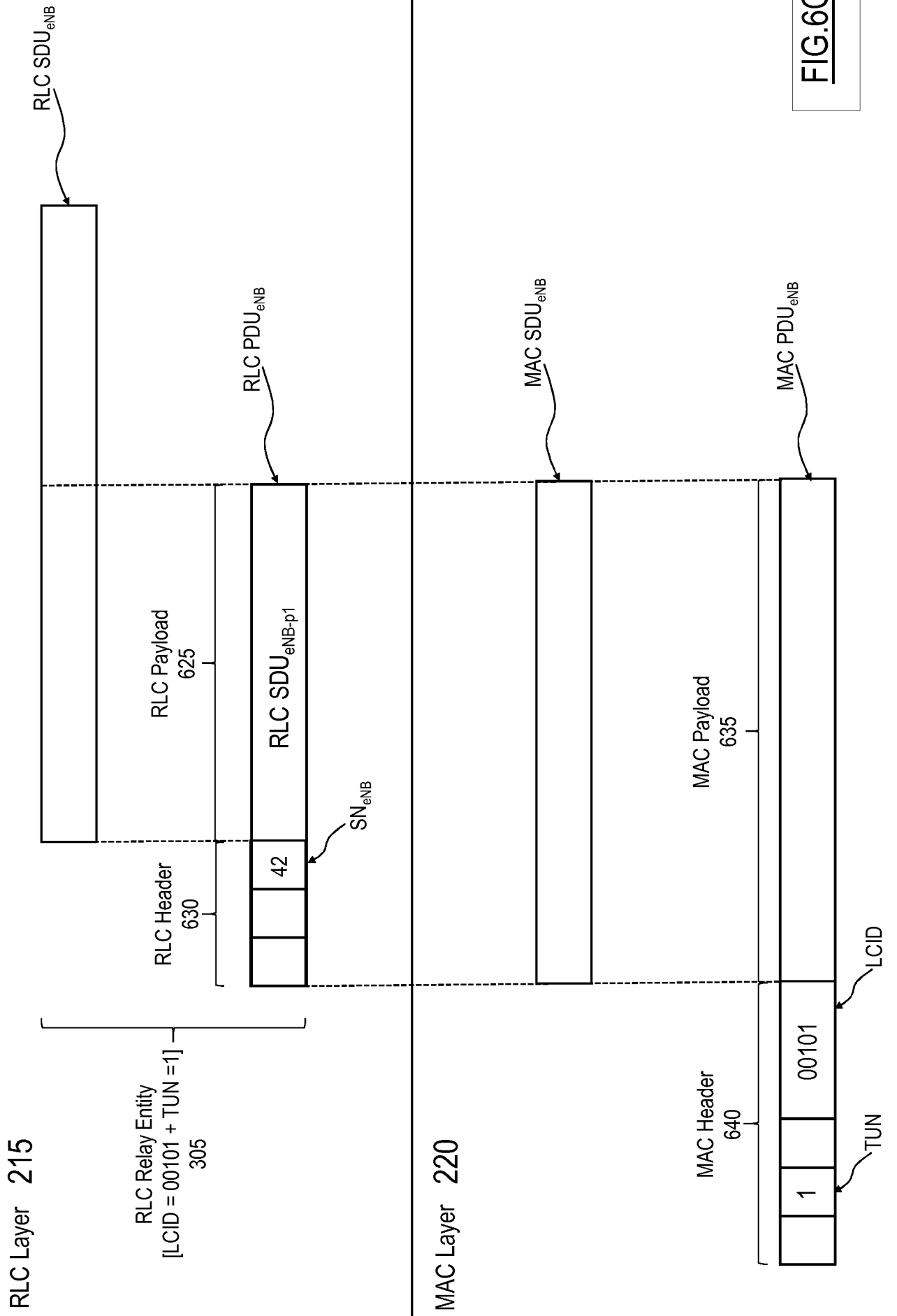

FIG.6C

MAC Layer 220

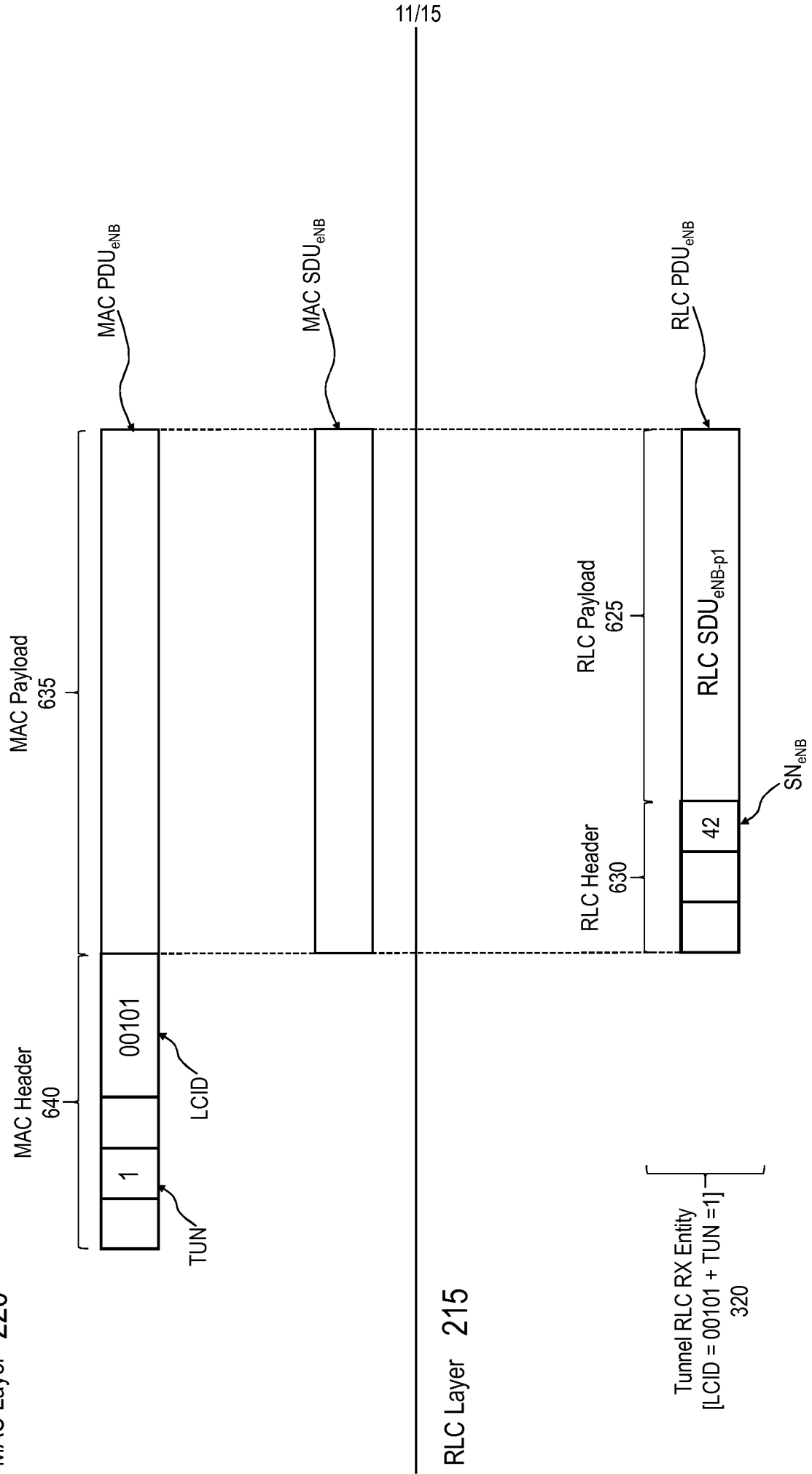

FIG.6D

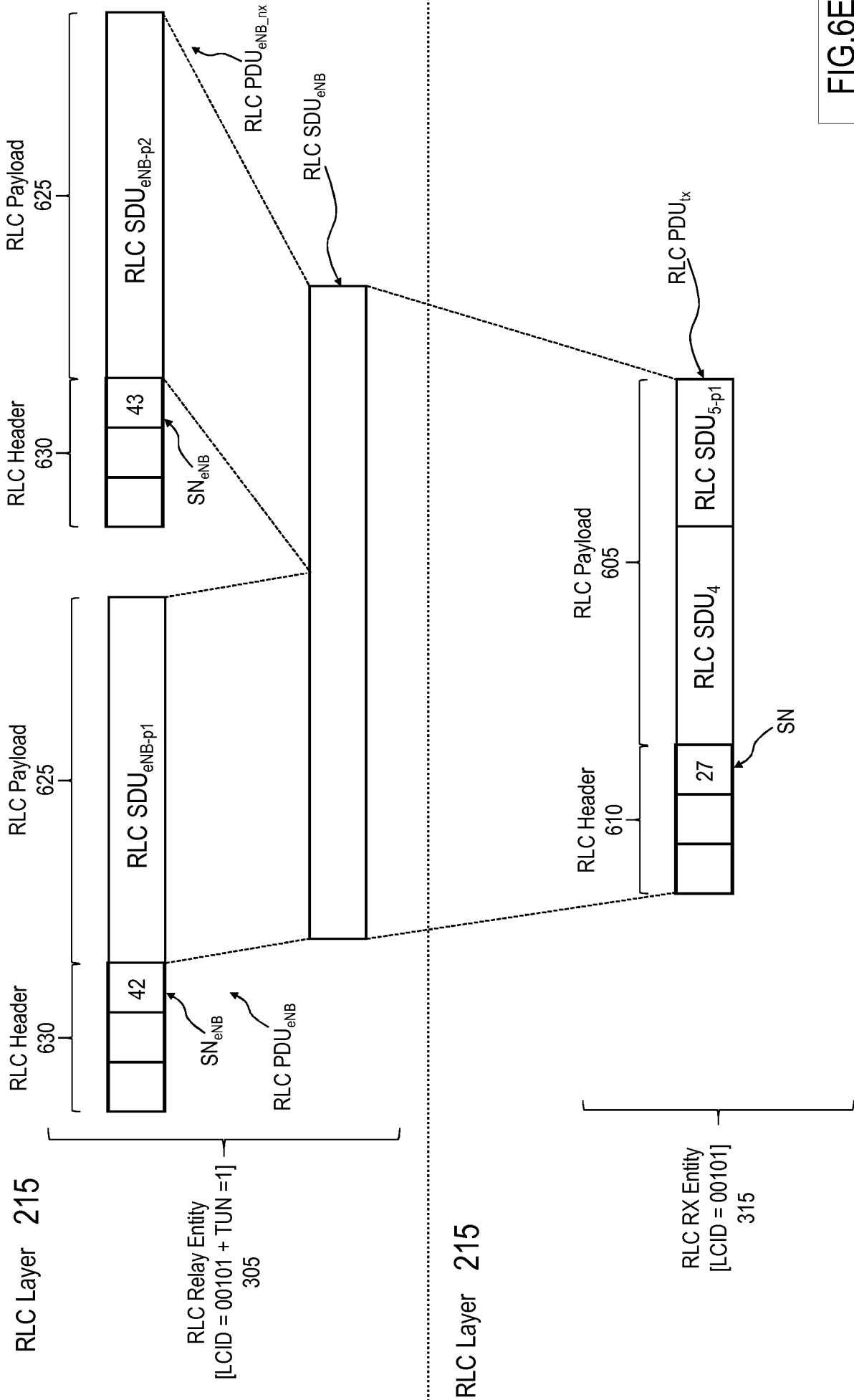

FIG.6E

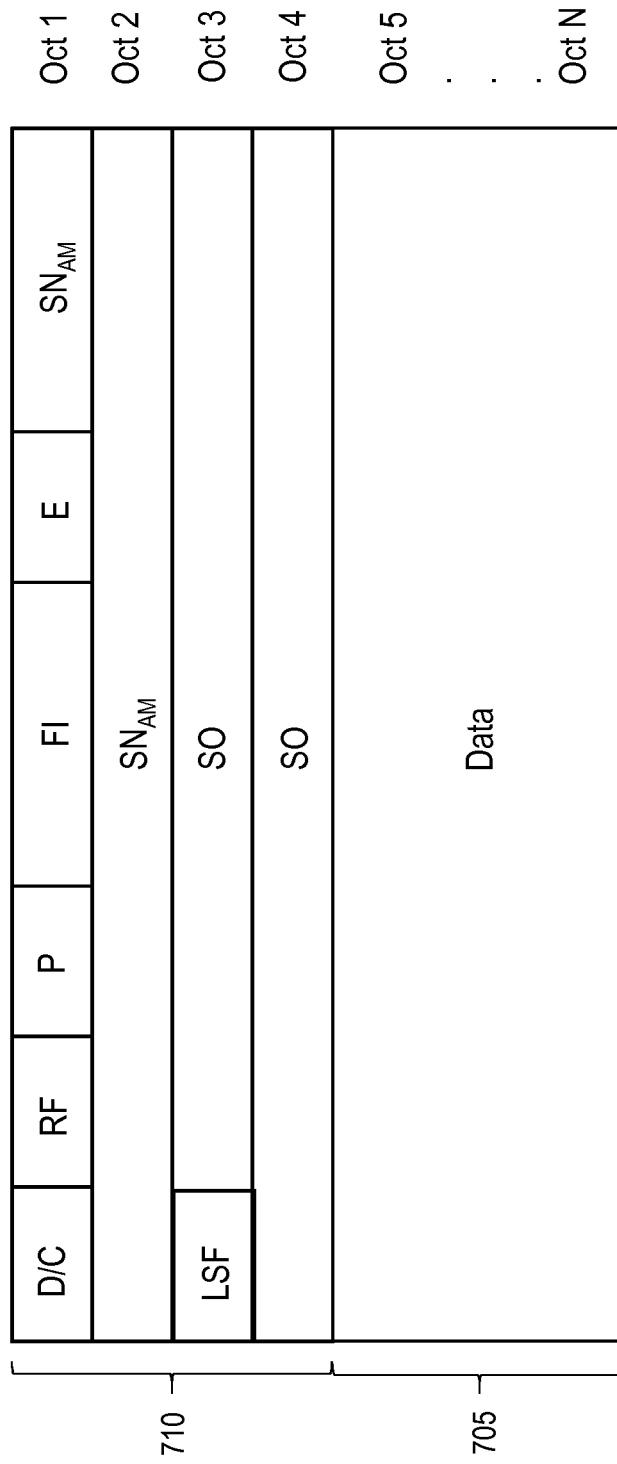

FIG.7

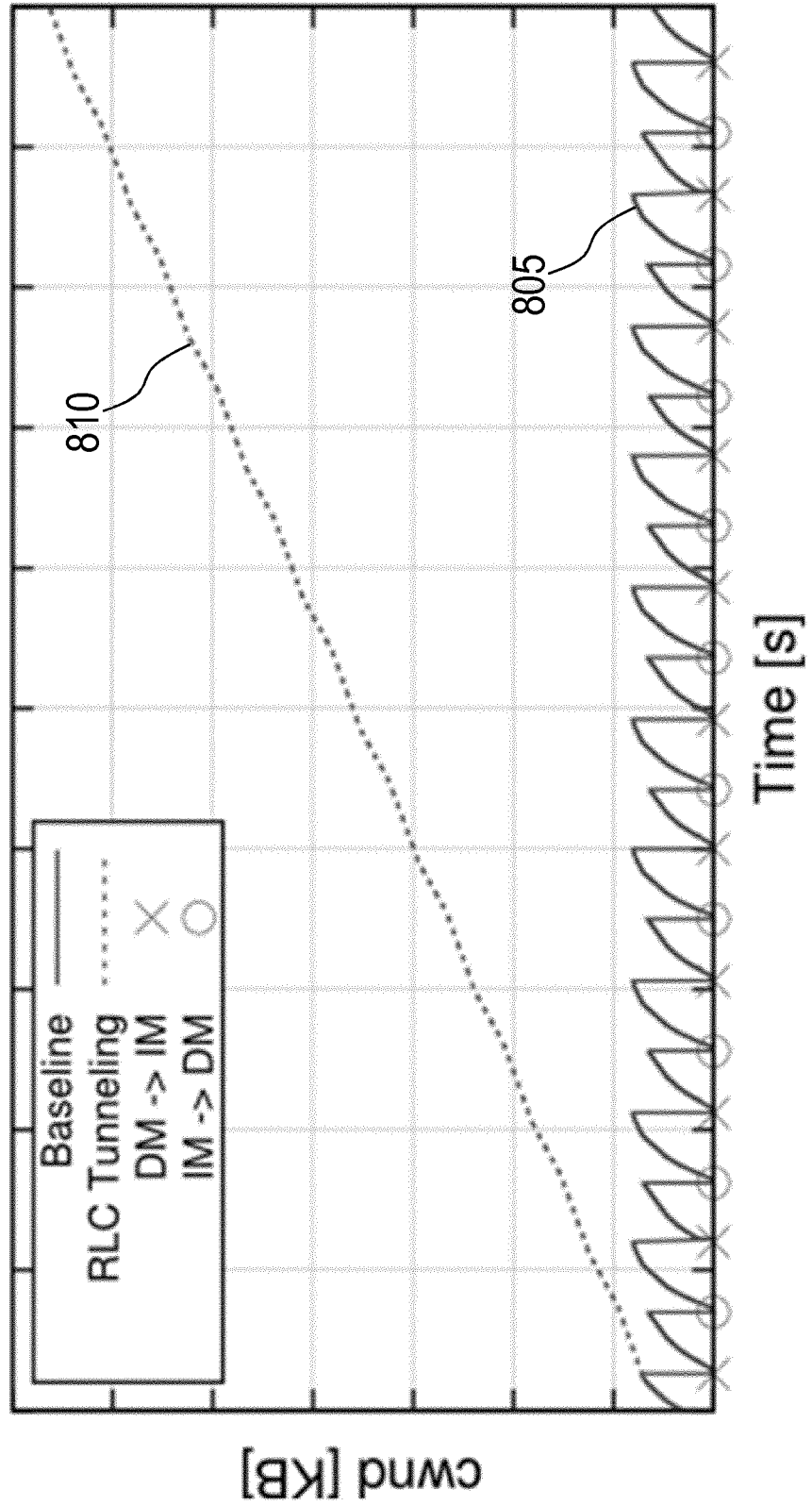
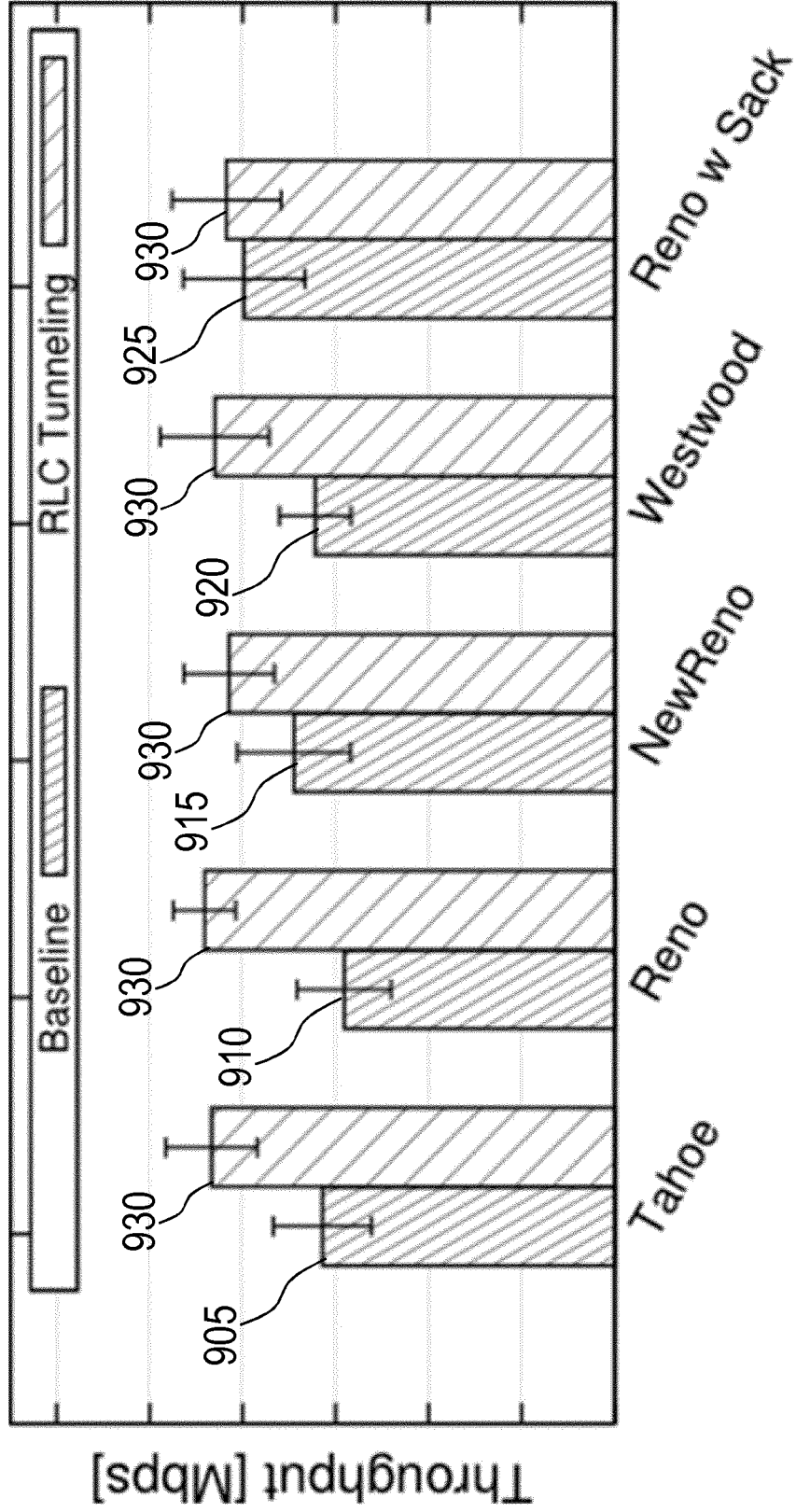

FIG.8

FIG.9



INTERNATIONAL SEARCH REPORT

International application No
PCT/EP2016/060864

A. CLASSIFICATION OF SUBJECT MATTER
INV. H04W76/04
ADD.

According to International Patent Classification (IPC) or to both national classification and IPC

B. FIELDS SEARCHED
Minimum documentation searched (classification system followed by classification symbols)
H04W

Documentation searched other than minimum documentation to the extent that such documents are included in the fields searched

Electronic data base consulted during the international search (name of data base and, where practicable, search terms used)
EPO-Internal, INSPEC, WPI Data

C. DOCUMENTS CONSIDERED TO BE RELEVANT

Category*	Citation of document, with indication, where appropriate, of the relevant passages	Relevant to claim No.
X	WO 2014/068464 A2 (RENESAS MOBILE CORP [JP]; RANTA JUKKA [FI]; IISAKKILA KAISU [FI]; TURT) 8 May 2014 (2014-05-08) the whole document -----	1-20

Further documents are listed in the continuation of Box C.

See patent family annex.

* Special categories of cited documents :

- "A" document defining the general state of the art which is not considered to be of particular relevance
- "E" earlier application or patent but published on or after the international filing date
- "L" document which may throw doubts on priority claim(s) or which is cited to establish the publication date of another citation or other special reason (as specified)
- "O" document referring to an oral disclosure, use, exhibition or other means
- "P" document published prior to the international filing date but later than the priority date claimed

- "T" later document published after the international filing date or priority date and not in conflict with the application but cited to understand the principle or theory underlying the invention
- "X" document of particular relevance; the claimed invention cannot be considered novel or cannot be considered to involve an inventive step when the document is taken alone
- "Y" document of particular relevance; the claimed invention cannot be considered to involve an inventive step when the document is combined with one or more other such documents, such combination being obvious to a person skilled in the art
- "&" document member of the same patent family

Date of the actual completion of the international search

30 November 2016

Date of mailing of the international search report

07/12/2016

Name and mailing address of the ISA/
European Patent Office, P.B. 5818 Patentlaan 2
NL - 2280 HV Rijswijk
Tel. (+31-70) 340-2040,
Fax: (+31-70) 340-3016

Authorized officer

Carnerero Álvaro, F

INTERNATIONAL SEARCH REPORT

Information on patent family members

International application No

PCT/EP2016/060864

Patent document cited in search report	Publication date	Patent family member(s)	Publication date
WO 2014068464 A2	08-05-2014	GB 2507491 A	07-05-2014
		US 2015289312 A1	08-10-2015
		WO 2014068464 A2	08-05-2014
