

STRETCHED-WIRE TECHNIQUES AND MEASUREMENTS FOR THE ALIGNMENT OF A 15GHz RF-BPM FOR CLIC*

S. Zorzetti[†], N. Galindo Munoz, M. Wendt, CERN, Geneva, Switzerland
L. Fanucci, Università di Pisa, Pisa, Italy

Abstract

For the Compact Linear Collider (CLIC) project at CERN, maintaining low emittance beams, as they are transported along the two independent 10-20 km long main linacs, is crucial. The beam trajectory therefore has to be very well aligned to the magnetic centre of the quadrupole magnets. A series of microwave cavity beam position monitors (BPM) is foreseen to detect the position of the beam along the main linacs to precisely monitor the beam trajectory in the circular beam pipe of only 8 mm diameter. The PACMAN project aims to demonstrate the pre-alignment of the magnetic field of a main CLIC quadrupole with the electro-magnetic centre of a 15 GHz RF-BPM to the required sub-micron accuracy. This paper focuses on stretched-wire measurements of a CLIC Test Facility (CTF) cavity BPM, to locate its electrical centre. Details of two measurement methods are discussed: RF signal excitation of the wire and analysis of RF signal transfer through the slot-coupled waveguides of the cavity, using the stretched wire as a passive target. This contribution will present the theory behind these measurements, their electromagnetic analysis and first, preliminary experimental results.

INTRODUCTION

To preserve the transverse emittance along the CLIC main linacs, the beam orbit needs to be steered with sub- μm accuracy and reproducibility along an optimal trajectory close to the electromagnetic center of the quadrupole magnets. This trajectory is foreseen to be measured using approximately 4800 high resolution cavity BPMs [1], located at each quadrupole along the beamline. At the CLIC Test Facility (CTF) a set of three cavity BPMs are currently under investigation. The PACMAN project [2] focuses on the study of the pre-alignment between the Main Beam Quadrupole (MBQ) and the resonant cavity Beam Position Monitor (RF-BPM). The pre-alignment methodology consist of characterizing the single components on separate test benches, integrating them on a dedicated support, aligning their respective electro-magnetic centres with stretched-wire measurement techniques. This paper summarizes the current status of the dedicated test stand and measurement setup for the cavity BPM.

* The PACMAN project is funded by the European Union's Seventh Framework Programme for research, technological development and demonstration under grant agreement no. 606839.

[†] silvia.zorzetti@cern.ch

CLIC RF-BPM

The CLIC RF-BPM consist of a resonant cavity coupled to four lateral waveguide slots with the signal picked up through coaxial connectors (Fig. 1) [3].

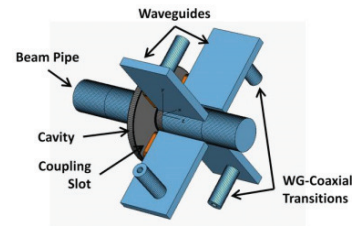

Figure 1: CLIC RF-BPM.

The fundamental mode of the cavity is a TM monopole mode at $\sim 11\text{GHz}$, with the TM dipole mode at $\sim 15\text{GHz}$. The lateral waveguides act as a high pass filter, suppressing the monopole mode while allowing the dipole mode to pass. Ideally, when the particle beam is centred into the RF cavity, the signal is zero, as the electric field of the dipole mode vanishes. In reality, because of mechanical imperfections, the electrical centre may not match the geometrical centre. The main task of the BPM test bench is therefore to accurately locate the electrical center.

MEASUREMENT METHODS

Two measurements methods have been identified, both using a conductive stretched-wire¹.

Signal Excitation

By means of a coaxial line the signal is propagated from the signal launcher to the BPM cavity. The wire is excited with a continuous sinewave at 15GHz and the BPM signal picked up through the lateral waveguides. With this method we are able to simulate the BPM behaviour as if it were excited by a particle beam (Fig.2).

To ensure a good transmission coefficient and to minimize reflections a hybrid PCB-coaxial transformer, operating at 15GHz, has been designed to launch the RF signal and to terminate the coaxial line configuration (Fig.3).

As the wire is excited and moved in the transverse plane of the BPM cavity, the signal picked up by one of the slot coupled waveguides is proportional to the electric field of the dipole eigenmode. When the wire is located in the centre of the cavity, the output signal is at a minimum.

The Slater theorem describes the dipole eigenfrequency shift in an RF cavity due to a metallic or dielectric perturbation,

¹ Cu-Be wire, 0.1mm diameter.

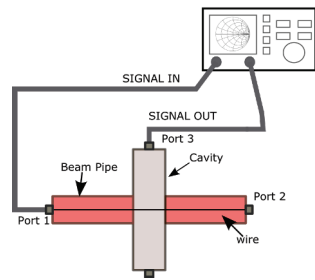

Figure 2: Signal excitation method setup.

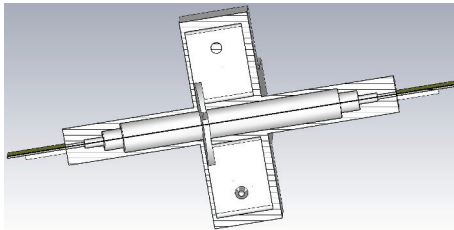

Figure 3: Model of the CLIC BPM Test Bench, including coaxial lines, terminations and signal launchers.

in this case the wire itself, which depends on its position. Because of this effect the linear zone of movement for a wire excited at a fixed frequency is reduced to $\sim \pm 300\mu\text{m}$, narrower than expected ($\sim \pm 500\mu\text{m}$). The final setup will have the BPM and the quadrupole rigidity mounted together, with their electromagnetic centres falling into the BPM linear range, to acquire a linear response with respect when the wire is in proximity of the quadrupole magnetic centre.

Perturbation Analysis

With this technique, the RF cavity BPM is excited by feeding a continuous sinewave at 15GHz through one of the four lateral waveguides, while looking at the signal picked up by the opposite or adjacent waveguide (Fig.4).

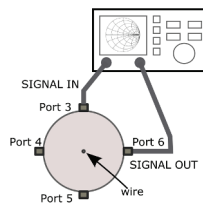

Figure 4: Perturbation analysis method setup.

The conductive wire represents a passive target, coupling with the electric field and draining power according to the amplitude of the field at that location. When the wire is located in the electrical center, the dipole E-field component is at a minimum, thus the power transmission between opposite waveguides is maximum.

On the other hand, the power transmission between adjacent waveguides is close to zero, as the RF-BPM has been designed to minimize the cross-talk between horizontal and vertical waveguides.

ISBN 978-3-95450-176-2

The plot Fig.5 compares the signals picked up by different waveguides, when the wire is excited ($|S31|$) and when the cavity is excited by the lateral waveguides: $|S43|$ referring to signal picked up by the adjacent port and $|S53|$ to the signal picked up by the opposite waveguides. From this plot we can anticipate a lower sensitivity around the electrical centre for the *perturbation analysis* method, as we are looking for maxima and minima rather than for a zero crossing slope. Nevertheless for integration purposes with the magnet and for allowing the metrology instrumentation to detect the position of the wire, the *perturbation analysis* is the preferred method for the final PACMAN test bench. In addition, the mechanics required for the coaxial line, necessary to transport the RF signal from the signal launcher to the cavity, would not allow a precise localisation of the wire with the *signal excitation* method.

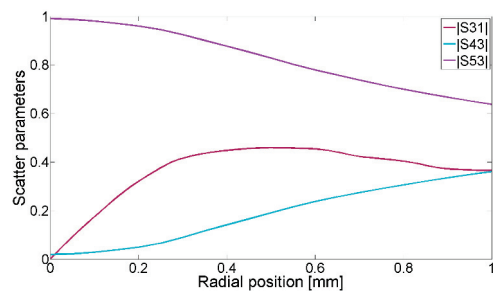

Figure 5: Equivalent E-field with respect to the wire's position performing measurements with the *signal excitation* method ($|S31|$) and to the *perturbation analysis* method ($|S43|$ adjacent waveguides and $|S53|$ opposite waveguides).

To more accurately locate the electrical center phase measurements may help. The plots in Fig.6 shows the phase jump when the signal is picked up from the adjacent port ($\angle S43$) in the *perturbation analysis* method, which is not in present on a same-axis measurement ($\angle S53$) when looking to opposite waveguides.

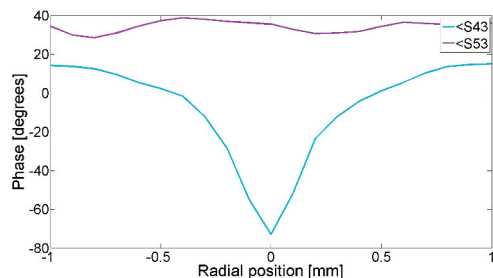

Figure 6: *Perturbation analysis* technique, phase measurements.

BPM TEST STAND

The BPM is mounted on a six-axis translation stage (hexapod), and moved with respect to a stretched wire. PXI technology from *National Instruments* is used to control the hexapod, to generate signals and acquire the response from

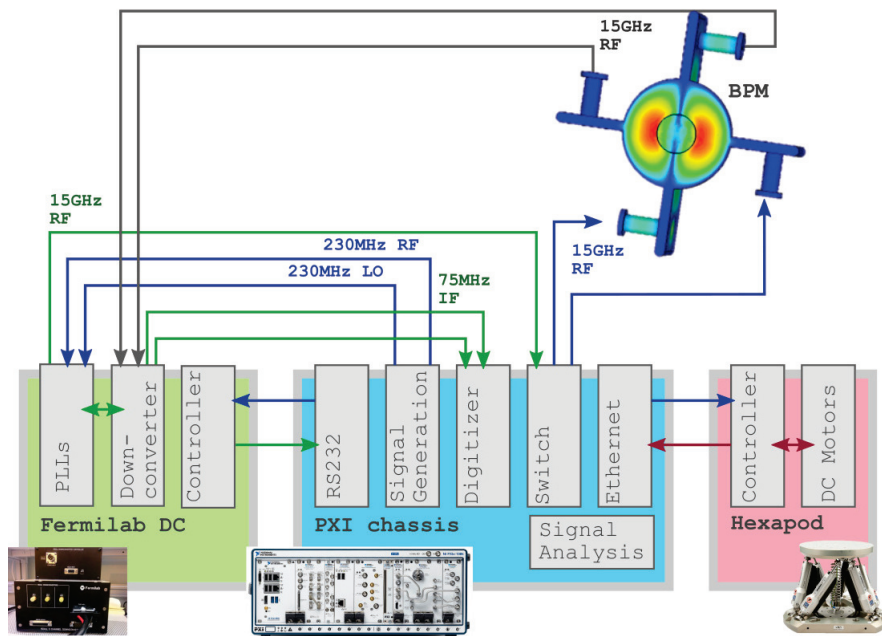

Figure 7: BPM Test Bench Block Diagram.

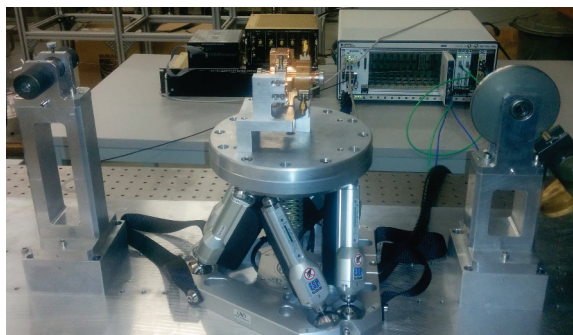

Figure 8: BPM Test Bench.

the BPM. A downconverter, which includes PLLs for RF and LO signal generation, is provided by *Fermilab* (US). It is used to downconvert the 15GHz signal to Intermediate Frequency (IF) of 75MHz. A block diagram of the BPM test stand is presented in *Fig.7*, while a picture of the setup is shown in *Fig.8*.

Hexapod

The Hexapod² is a 6 Degrees of Freedom (DOF) translation stage with sub-micrometric resolution³. It has been validated with a *Leitz* Coordinate Motion Machine (CMM)⁴. Four spherical targets were mounted on the hexapod plate with the CMM sensor detecting the 3D position of each of those targets. The position of the device is determined by interpolating a plane between three of the four targets, pro-

jecting the fourth one onto the same plane and finding the mid-point.

In particular, the repeatability of the instrument was tested. The *uni-directional repeatability* is defined as the ability of the instrument to achieve a given position by attempting from a single direction, the *bi-directional repeatability* as the ability of the instrument to achieve a given position by attempting from different directions [4].

The results plotted in *Fig.9*⁵ refer to the movement of the hexapod on the z-axis⁶ with a step size of 5µm.

While the uni-directional repeatability specification has been confirmed (the error is estimated as 0.25µm, which corresponds to the CMM uncertainty), the hexapod failed the test on the the bi-directional repeatability, as it is above 2µm. Though the backlash effect can be compensated from the repeatable behaviour of the hexapod around the same trace.

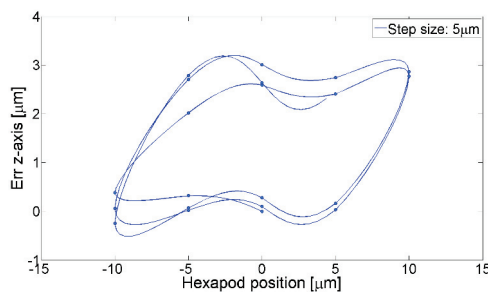

Figure 9: Hexapod validation result: hysteresis and repeatability evaluation on the z-axis.

² HXP100-MECA from *Newport*.

³ (X,Y,Z) Minimum step size: (0.5, 0.5, 0.25)µm;

(X,Y,Z) Bi-directional repeatability: (4, 4, 2)µm.

⁴ CMM uncertainty of $\pm(0.3\mu\text{m} + L/1000)$, where L is the dimension of the object under test in mm

⁵ Load on the support: 5Kg.

⁶ The x-y plane is parallel to the hexapod plate, the z-axis or vertical axis is orthogonal to the x-y plane

Exploiting the good uni-directional repeatability, the measurement strategy was to scan the BPM cavity from a given starting point, moving on a single axis, then to reset the hexapod and scan a parallel line in the same direction.

Downconverter

The downconverter unit designed by *Fermilab*, also used for the cavity BPM studies at CTF, serves as the signal source and RF analogue signal processing unit. Two PLLs multiply the $\sim 230\text{MHz}$ Local Oscillation (LO) and RF signals, generated by the *National Instruments* PXI RF generators, 64 times to 15.075GHz and 15.000GHz respectively. The 15.000GHz signal feeds the cavity BPM port via the RF switch, while the 15.075GHz LO signal feeds a mixer, which downconverts the RF signal to 75MHz . The RF and IF stages of each of the three downconverter channels are equipped with variable gain and attenuation, delivering an overall dynamic range of 80dB [5].

National Instruments PXI and Controls

The PXI technology from *National Instruments* is used to control the downconverter and perform signal generation, acquisition and processing; while a switch board is used extend the measurement to four ports. A LabVIEW interface (Fig. 10) acquires the RF data and controls and monitors the hexapod movements.

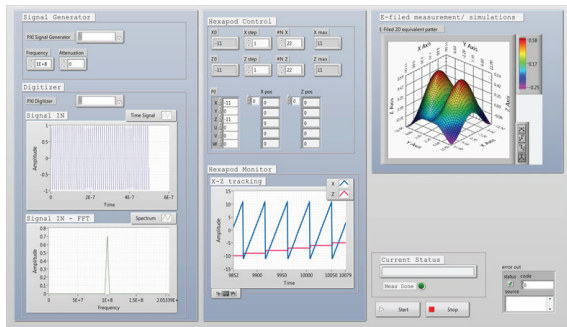

Figure 10: LabVIEW interface, in this version the E-field is rebuilt by simulations.

The LabVIEW control software is composed of three main items:

- **PXI Hardware control**

The electronic boards are controlled inside the PXI chassis. The signal is generated with user-configurable parameters. The IF signal from the downconverter is digitized and analyzed in the frequency domain.

- **Hexapod controller**

The hexapod is controlled through an Ethernet connection. The interface allows setting the starting point and the step-size in the two scanning dimensions.

- **Signal analysis**

The IF signals are analysed and a quantity equivalent to the E-field component is visualized in a 3D graph

with respect to the wire x-y position, with the third dimension being the measured amplitude of the electric-field component.

EQUIVALENT E-FIELD PATTERN RECONSTRUCTION

Employing the hardware and software systems presented in the previous section, the RF-BPM cavity was scanned using the wire as a probe while the dipolemode intensity chart was recorded (Fig. 5).

The initial measurements have been carried out with the *perturbation analysis* setup, considering only transmission between opposite waveguides; further phase measurements between adjacent waveguides are foreseen. As the PXI electronics was not yet available only a limited number of samples could be taken, which underlines the necessity for having an automatic test bench. The scan starts with a wide step-size of the hexapod, which decreases to smaller steps when approaching to the electrical center. Fig. 11a to 11c show the progression from a step-size of $500\mu\text{m}$ to $20\mu\text{m}$.

A transverse cut of the intensity diagram in Fig. 11c is displayed in Fig. 12, showing a gradient around the electrical centre of $0.59\text{m dB}/\mu\text{m}$. The aim is now to increase this resolution by refining the measurement method.

Resolution and Repeatability Studies

Studies on the BPM resolution and repeatability have also been undertaken with the goal of demonstrating a nanometric resolution, anticipated as 50nm by simulations and not yet proved.

Fig. 13 plots the resolution and bi-directional repeatability results demonstrated so far. Starting from a given point approaching the electrical centre, one position has been recorded (P_0 in the graph); moving on a single $1\mu\text{m}$ step on the x-axis ($P_0 - 1\mu\text{m}$) a $10\text{m dB}/\mu\text{m}$ resolution has been proved, obtaining a $\sim 2.5\text{m dB}$ bi-directional repeatability by moving a same step size on the same axis in opposite direction ($P_0 + 1\mu\text{m}$).

CONCLUSION

The BPM test bench has been studied and several measurement methods, promising different resolution and sensitivity, have been identified. Results achieved so far are encouraging and we look forward to progress on this path, with the aim of testing all the identified measurements methods, to compare their precision in the location of the electrical centre and proving the nanometric resolution of the RF-BPM.

ACKNOWLEDGMENT

My sincere thanks go to the NI team which followed me during my secondment at National Instruments in Hungary, in particular Botond Barabas, Erika Kun, and Peter Nemeti. I would also like to thank Nathan Eddy and Brian J. Fellenz from Fermilab for the work on the RF downconverter unit.

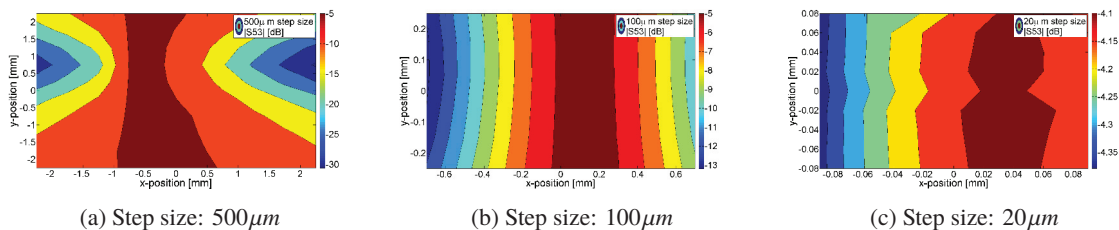

Figure 11: E-field pattern reconstruction by RF measurements in the area of the electrical center of the RF-BPM.

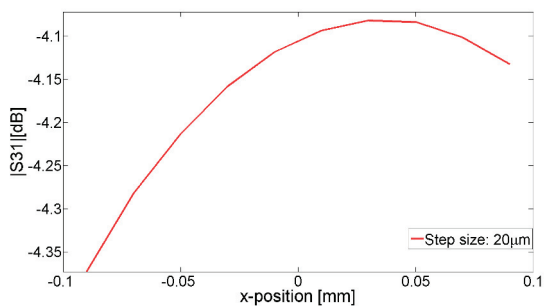

Figure 12: Transverse cut of Fig. 11c, $20\mu\text{m}$ step size.

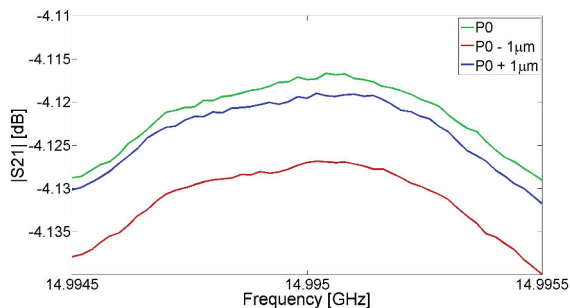

Figure 13: $1\mu\text{m}$ resolution results.

REFERENCES

- [1] H. Schmickler et al., *Submicron multi-bunch BPM for CLIC*, FERMILAB-CONF-10-292-AD.
- [2] H. Mainaud Durand et al., “Status of the PACMAN project”, *these proceedings, IBIC’ 15, Melbourne, Australia (2015)*.
- [3] N. Chritin et al. *A high resolution cavity BPM for the CLIC Test Facility*. FERMILAB-CONF-10-291.
- [4] Newport website: <http://www.newport.com/Motion-Basics-and-Standards/140230/1033/content.aspx>
- [5] J. R. Towler et al., "Development and Test of High Resolution Cavity BPMs for the CLIC Main Beam", *these proceedings, IBIC’ 15, Melbourne, Australia (2015)*.