

L.E. Herranz (CIEMAT), S. Paci (UNIPI)

MUSA was founded in HORIZON 2020 EURATOM NFRP-2018 call on

"Safety assessments to improve Accident Management strategies for Generation II and III reactors"

On June 15th, 2018 MUSA obtains the NUGENIA label that recognizes the excellence of the project



MUSA Consortium

29 Organizations (25% non EU)
4 years duration
630 person months overall costs
€ 5,768,452.50

Advisory Board

non-partners that can guide partnership with reference to the needs and viewpoints of key stakeholders

End User Group

members of communities on which MUSA outcomes might have an effect

Numerical tools are widely used to assess the Nuclear Power Plants (NPP) behaviour during postulated Severe Accidents (SA). Considering the complexity of the processes taking place during a SA and the inherent nature of numerical codes (numerics, spatial discretization, etc.), **it is mandatory to quantify their embedded uncertainties** taking into account the latest developments in methods and algorithms as well as the availability of computing resources.

Mathematical tools for quantification of code uncertainties and sensitivities have been under development for many years, with a huge accumulated experience in performing Uncertainty Quantifications (UQ) with Best Estimate (BE) system codes, partly because of new requirements in regulations of some countries as part of the NPPs licensing processes. This is so far not the case for SA codes and only a few investigations have been focused on SA and UQ.

MUSA has an "innovative research agenda" in order to move beyond the state-of-the-art regarding the predictive capability of SA analysis codes by combining them with the best available or improved UQ tools. By doing so, not only the prediction of timing for the failure of safety barriers and of radiological Source Term (ST) will be possible, but also the quantification of the uncertainty bands of selected analysis results, considering any relevant source of uncertainty, will be provided.

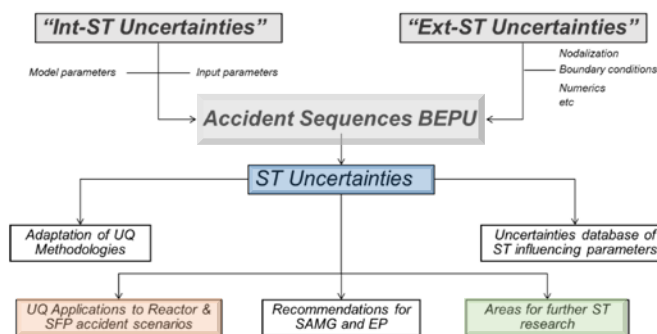

Objective of the MUSA project

Assess the capability of SA codes when modelling reactor/ SFP accident scenarios of GEN II, GEN III designs

- Identification of UQ methodologies to be employed, with emphasis on the effect of both existing and innovative SAM measures on the accident progression, particularly those related to the ST mitigation
- Determination of the state-of-the-art prediction capability of SA codes regarding the ST that potentially may be released to the external environment, and to the quantification of the associated code's uncertainties applied to SA sequences in NPPs and SFPs

MUSA Work Packages WP

- WP MUSA COOrdination (MUCO), coordinated by CIEMAT
- WP2 Identification & Quantification of Uncertainty Sources (IQUS), coordinated by GRS
- WP3 Review of Uncertainty Quantification Methods (RUQM), coordinated by KIT
- WP4 Application of Uncertainty Quantification Methods against Integral Experiments (AUQMIE) by ENEA
- WP5 Uncertainty Quantification in the Analysis and Management of Reactor Accidents (UQAMRA) by JRC
- WP6 Uncertainty Quantification and Innovative Management of SFP Accidents (IMSFP) by IRSN
- WP7 COmmunication & REsults DISsemination (COREDIS) coordinated by UNIPI

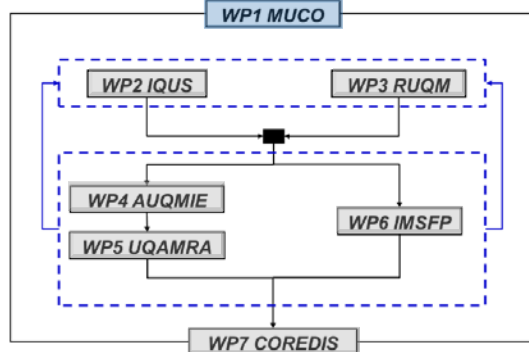

Dissemination of Knowledge

Special attention for knowledge transfer towards young researchers and Masters/PhD students

- Production of public learning modules to be published in the MUSA open website.
- Mobility programme under which university students and young researchers go to internship programmes
- Production of a lecture on "Uncertainty Quantification in Severe Accident Analyses" for the different international Courses that might be given on Severe Accidents and/or on "uncertainties"

MUSA Education activities will be carried out in a close collaboration with the ENEN Network

Perspectives

- MUSA will mean a better exploitation of research previously performed within the EU framework
- Over the years, reliable and experienced teams of modellers and analytical teams have been built-up, and MUSA is a unique opportunity to achieve real feedback among them
- In addition, MUSA encourages cooperation in research, innovation and young generation's formation

Finally, MUSA will be an open results project for its importance on forthcoming SA analyses

7 WP leaders



UNIVERSITÀ DI PISA



CONTACT:

Prof. L.E. Herranz
CIEMAT Madrid
luisen.herranz@ciemat.es