

Simulation Platform for Analyzing Battery Parallelization

R. Di Rienzo, F. Baronti, R. Roncella, R. Morello, and R. Saletti
Dip. di Ingegneria dell'Informazione, Università di Pisa, Italy

Abstract—This paper discusses a simulation platform for predicting the behavior of a battery system comprising two batteries, which can be parallelized in a controllable way. The model of the battery, the load and the parallelization algorithm is developed and simulated in MATLAB® Simulink environment. The simulation platform and the proposed parallelization algorithm are validated in a real gardening application. The simulation results prove to be useful for further investigation into the benefits of battery parallelization in terms of reduced battery aging and improved energy efficiency.

I. INTRODUCTION

Small-format lithium-ion batteries are the dominant choice in portable electronic devices, thanks to their high power and energy densities. An electronic circuit called Battery Management System (BMS) is the typical companion for a lithium-ion battery to avoid electrical and thermal abuse [1]. In the last few years, there has been a growing interest in medium-format lithium-ion batteries to replace older battery technologies or enable new uses in a wide range of medium power applications, *e.g.*, power tools, lawn and gardening systems. While the performance benefits of adopting the lithium-ion battery technology are unquestionable in these applications, the associated cost is still relevant, the battery being often the most expensive component of the system.

We note that large families of tools use batteries with the same nominal voltage, but different capacities in order to meet the specific power and energy requirements of a particular tool. The battery consists of one or more elementary cells (usually up to 4) connected in parallel to form groups of cells. Typically 10 or 12 groups are series connected to reach the desired voltage level. To exploit the advantages of the economies of scale, it is beneficial to have a standard battery with capacity and cost suitable for the less demanding tools, which are the most widespread. In this scenario, battery parallelization becomes really attractive to meet the energy requirement of the more demanding tools [2]. Assuming that the power requirement could be met with a single standard battery, not only does the parallel connection of two batteries double the application runtime, but also halves the current flowing in each battery. This turns into a slower degradation of the battery cells with respect to discharging the two batteries sequentially [3].

Cell or battery parallelization requires particular attention as mismatches in the state of charge (SOC), capacity and internal resistance may lead to degraded performances and accelerated aging. The impact of cell-to-cell variations on the cycle life

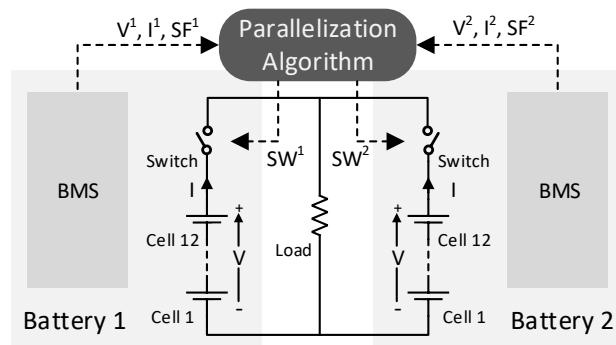

Fig. 1. Block diagram of the simulated battery system.

of parallel connected cells has been analyzed in [4], [5]. In [6], the authors focused on the arrangement (series and/or parallel) of the cells in the battery to maximize the energy which it can provide to the load. Usually, the cell parallel connection is hardwired, whereas the parallelization of battery strings (one or more batteries series-connected) is controlled in software by means of dedicated power switches [7]. This gives the flexibility to introduce a parallelization algorithm, which should maximize the battery lifetime and minimize the conduction losses over the internal resistance of the batteries and on the resistance of the parallelization switches. This is quite an unexplored research topic, which could definitely benefit from the availability of a simulation framework that can predict the battery system behavior in a wide range of operating conditions.

In this work, we propose a simulation platform to investigate the parallelization of medium-format batteries effectively. Both the physical components (batteries and load) and the control part (parallelization algorithm) of the system are modeled and simulated, thus making it possible to develop and test the parallelization strategy. The paper is organized as follows. Section II describes the simulation platform, while the proposed battery parallelization algorithm is presented in Section III. Simulation results are discussed in Section IV and some conclusions are drawn in Section V.

II. SIMULATION PLATFORM

The developed simulation platform aims at predicting the behavior of a battery system comprising two batteries, which are connected to the load according to a parallelization algorithm that controls the protection switch in each battery. A schematic representation of the simulated battery system is shown in Fig. 1. The system is modelled in MATLAB®

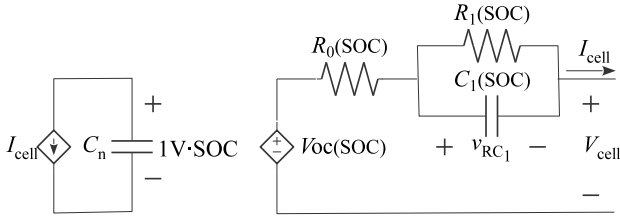

Fig. 2. 1-RC equivalent circuit model.

Simulink environment. Simscape blocks are used to represent each battery and the load, whereas the Stateflow environment is adopted to describe the parallelization algorithm.

A. Battery model

The battery behavior is simulated combining the instances of a lithium-ion cell model, a basic BMS model and the switch block available in the Simscape libraries. Twelve cell model instances are series-connected to simulate the battery. The cell and BMS models are described below.

1) *Cell model*: The 1-RC equivalent circuit model (ECM) shown in Fig. 2 is used to predict the cell electrical behavior. The circuit is composed of two parts. On the left hand side of Fig. 2, the capacitor C_n with a value equal to the cell capacity expressed in Coulomb is used to track the cell SOC. The right hand section of the circuit predicts the cell terminal voltage, as the sum of the Open Circuit Voltage (V_{OC}), the voltage across the resistor R_0 , which models the ohmic resistance of the cell, and the voltage of the R_1 and C_1 group, which accounts for the fast dynamics due to the charge transfer and the double layer effects [8]. V_{OC} can be assumed as a function of SOC only and it is a characteristic of the specific lithium-ion technology used. It is modeled by a dependent voltage source controlled by SOC and the relationship between V_{OC} and SOC is stored in a LookUp Table (LUT).

The 1-RC ECM is capable of predicting the fast dynamics of a lithium-ion cell, assuming that the model parameters (R_0 , R_1 and C_1) vary with the operating condition, which is represented by the cell SOC, temperature, and current. This parameter dependence can be modeled by a multi-dimensional LUT, but it requires an extensive test campaign to be carried out on the cell to obtain the LUT values. In this work, only the SOC dependence is considered.

2) *BMS model*: The implemented model simulates the monitoring and protection functions of a BMS. In particular, it checks if all the predicted cell voltages and the battery current lie within the safe operating area (SOA). If this happens, it asserts the safety flag and enables the battery switch to be turned on. In addition to the safety flag, the model computes the overall battery voltage V from the cell voltages.

B. Parallelization algorithm model

The parallelization algorithm is implemented in a finite state machine (FSM). The FSM receives as input the safety flag SF^n , the voltage V^n and the current I^n ($n = 1, 2$) from the two batteries and generates the signals SW^1 and SW^2 , which control the two switches, one in each battery. This approach

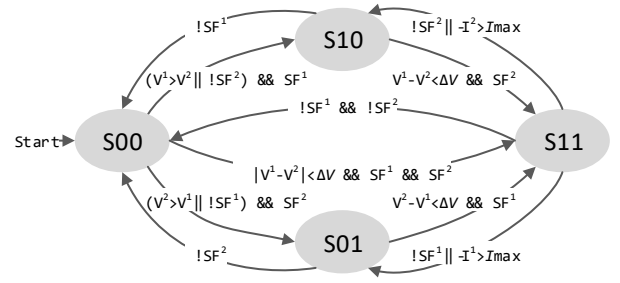

Fig. 3. Flow diagram of the finite state machine implementing the parallelization algorithm. V , I and SF are respectively the battery voltage, current (positive during discharge) and safety flag. The symbols $!$, $\&\&$ and $||$ mean the logic not, and, or operations, respectively.

is quite flexible and powerful, as it allows us to test various parallelization policies easily and to translate them into C code automatically. A possible parallelization policy is presented in the following section.

C. Load model

The load model discharges the battery system with a desired power profile. It is implemented by means of a Simscape controlled current source block, whose instantaneous value is the desired power divided by the simulated voltage of the battery system.

III. PARALLELIZATION ALGORITHM

The key goal of the parallelization policy is to maximize the sharing of the current drawn by the load between the two batteries, while maintaining every battery cell inside the SOA. We note that at the beginning of the discharge, the two batteries are likely to have different SOC. This yields a voltage mismatch that can cause a potentially harmful instantaneous current to flow from the most charged to the least charged battery, if they are parallel connected. Being I_{max} the maximum charging current of the used battery cells, the parallel connection can be established only if the absolute voltage difference is less than ΔV defined as

$$\Delta V = (R_0^1 + R_0^2)I_{max} \quad (1)$$

where the R_0^1 and R_0^2 are respectively the ohmic resistance of battery 1 and 2.

The above premise can be translated into the flow diagram shown in Fig. 3. It consists of 4 states (S00, S10, S01 and S11). S00 represents the condition in which both battery switches are off, S11 where the two batteries are connected in parallel, whereas S10 and S01 are the states in which only battery 1 or 2 powers the load, respectively.

The FSM starts from the state S00. If the safety flag of both batteries is asserted and their absolute voltage difference is less than ΔV , then the FSM goes to the state S11, in which the two batteries are discharged in parallel. Assuming that the two batteries are identical, they reach the full discharge condition at the same time and the FSM moves back to S00. On the contrary, if for any reason one battery, battery 2 for instance, discharges quicker than the other, the FSM goes to

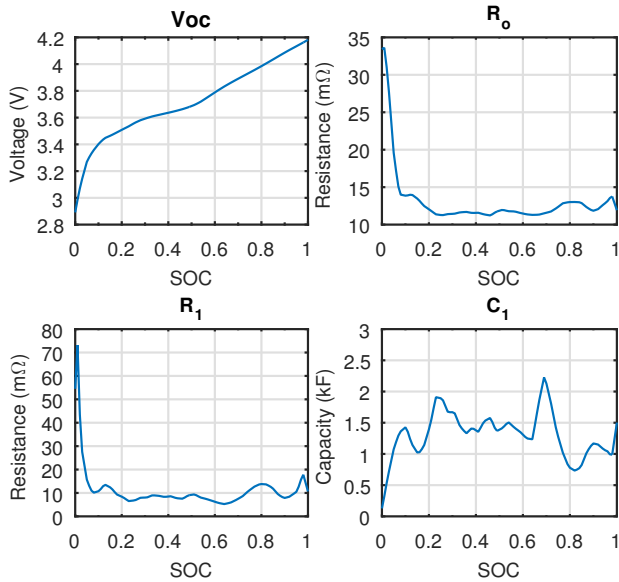

Fig. 4. Dependence of the cell parameters on SOC.

S10, in which only battery 1 powers the load. This state is also reached from S00 when battery 1 SOC is initially higher than that of battery 2 yielding a voltage difference greater than ΔV . Only battery 1 is discharged in this state. When the voltage difference becomes less than ΔV , battery 2 can be connected in parallel and the FSM moves again to the state S11. It may happen that the parallelization condition ($|V^1 - V^2| < \Delta V$) is reached on a peak value of the load current and does not hold when the load current decreases. This causes a current absolute value higher than I_{\max} to charge battery 2. Should this happen, the FSM recognizes it and goes back to the S10 state. As it can be seen in Fig. 3, the FSM exhibits a symmetric behavior with respect to the battery position, that is, the state S10 is equivalent to S01 if we exchange the battery position.

We note that the above described parallelization algorithm can easily be generalized to a number of batteries larger than two. In fact, the most charged battery is always connected to the load and any other is if both the voltage and current parallelization conditions are satisfied.

IV. SIMULATION RESULTS

A. Case-study

The developed simulation platform has been used to analyze the performance achievable by parallelizing two batteries in a gardening application. The battery used in the application consists of 12 series-connected groups of two parallel-connected lithium-ion cells. The latter have a 3.6 V nominal voltage, a 2500 mA h nominal capacity, a 18650 cylindrical case and are manufactured by LG Chem (with part number LGDBHE21865). The battery has a nominal voltage of 43.2 V and a nominal capacity of 5 A h.

To extract the parameters of the 1-RC ECM, a pair of parallel-connected cells has been characterized using the conventional pulsed current test [9] in a thermal chamber at the

temperature of 25 °C. The extracted value for V_{OC} , R_0 , R_1 , and C_1 , as a function of SOC, are seen in Fig. 4. The same set of parameters has been used for every battery cell. Cell-to-cell parameter variations are thus neglected in this work, where we focus on assessing the performance of the battery parallelization algorithm under different SOC mismatches. However, the simulation platform allows us to investigate the battery behavior also when the cells are not fully matched.

The load model has been chosen according to the power profile for the considered gardening application, which has been obtained by experimentally measuring the power drawn by a gardening tool during an 8 min mission. This power profile has a mean value of 327 W, a peak value of 753 W and is periodically repeated during the simulations. Furthermore, the parallelization algorithm has been parametrized with $I_{\max} = 8$ A (as the maximum charging current for LGDBHE21865 cells is 4 A), which yields $\Delta V = 0.21$ V, being $R_0^1 = R_0^2 \approx 13$ m Ω (see Fig. 4)

B. Battery parallelization simulation results

Given the above described case-study, several simulations have been carried out, in which the initial SOC value of battery 1 is kept constant to 100 % and that of battery 2 is varied from 100 % to 0 %. The upper bound corresponds to the situation in which both batteries are fully charged, whereas the lower bound is equivalent to powering the load with only one battery.

For example, Fig. 5 shows the simulated voltage and current of the two batteries, when battery 2 SOC is initialized at 70 %. At the beginning of the test, the FSM goes into the S10 state and remains in this state for about 1 min until battery 1 voltage V^1 is no longer greater than $V^2 + \Delta V$. When this occurs, the FSM moves to the S11 state and the batteries are connected in parallel. However, battery 1 SOC is still higher than that of battery 2 and the load current is not evenly shared between the two batteries, as it can be seen in Fig. 5 during the minutes which follow. In fact, there are instants in which battery 2 is recharged by battery 1. Should the charging current have exceeded I_{\max} , the FSM would have moved back to the S10 state, to avoid damages of the battery 2 cells. As the discharge proceeds, the SOC of the two batteries tends to self-balance by the end of the application runtime. Only the first 32 min of the simulation are shown to appreciate the algorithm behavior.

The results of four simulations are summarized in Table I. In every simulation, battery 1 is initialized at 100 % of SOC, whereas the second one is initialized at 100 %, 70 %, 40 % and 0 %, respectively. The table shows the comparison of the available energy, the delivered energy and the application runtime as derived from the simulations.

To estimate the available energy in a fully charged battery, a simulation of a full discharge at 1 C has been carried out. This value has been used to estimate the total available energy of the battery system in the four considered cases. The results show that the ratio between the energy delivered to the load and the available energy in the battery system increases when the full parallelization of the batteries occurs, achieving a better global efficiency in the energy transfer, as expected.

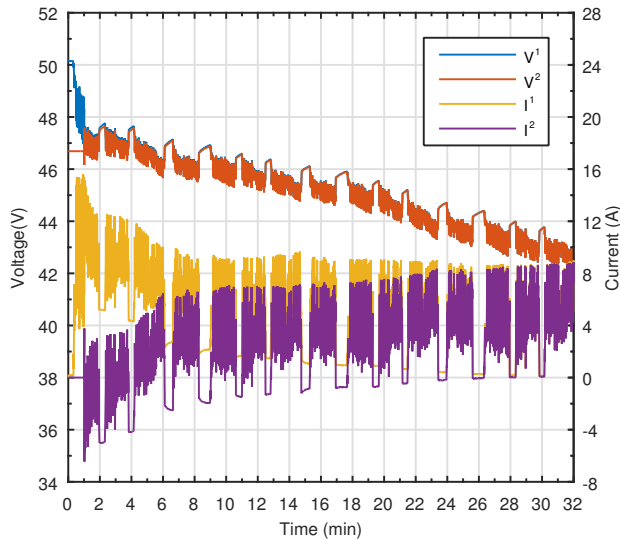

Fig. 5. Voltage and the current of the two batteries in the first 32 min of the simulation, where, battery 1 is initialized at 100% of SOC and the second one at 70%.

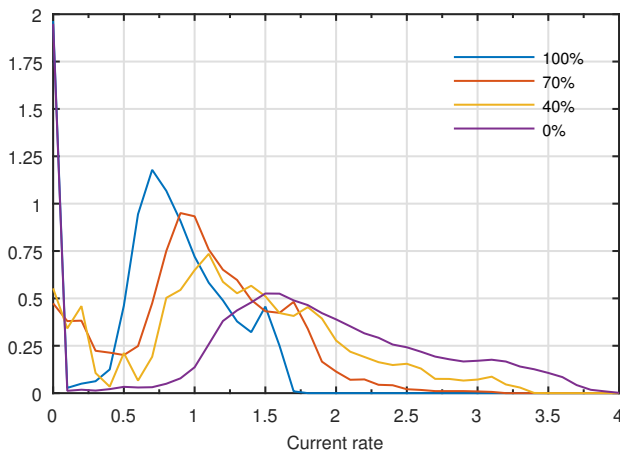

Fig. 6. Probability density function of the current rate which flows in the battery 1 when it is initialized at 100% of SOC, and battery 2 is initialized at 100%, 70%, 40% and 0%, respectively.

Furthermore, the simulation platform allows the quantitative evaluation of another important benefit of battery parallelization. Fig. 6 shows the probability density function (pdf) of the current value which flows in battery 1 in the four simulations described above. Considering the single battery case, *i.e.*, battery 2 is initialized at 0% of SOC, the mean value of the current delivered by battery 1 is 8.04 A which corresponds to a 1.6 C. This value is more than twice if compared to the mean current value which flows in battery 1 when both batteries are fully charged and the parallelization is exploited to the full. In fact, this current is equal to 3.78 A which corresponds to 0.75 C. The quantitative evaluation of the battery average current rates allows us to show the beneficial effects on battery aging due to a reduced stress in the battery.

TABLE I
PERFORMANCE COMPARISON OF DIFFERENT PARALLELIZATION CASES

| Battery 2 | Available energy | Energy delivered | Runtime |
|-----------|------------------|------------------|---------|
| 0 % SOC | 210 W h | 204 W h | 37 min |
| 40 % SOC | 285 W h | 282 W h | 51 min |
| 70 % SOC | 350 W h | 350 W h | 64 min |
| 100 % SOC | 421 W h | 421 W h | 77 min |

V. CONCLUSIONS

This paper has presented a simulation platform for predicting the behavior of the parallel connection of two batteries controlled by a parallelization algorithm. The model of the batteries, load, and the proposed parallelization algorithm has been developed in MATLAB[®] Simulink environment. The platform has successfully been used to simulate the parallelization of two medium-format batteries for a gardening application in a real use case. Simulation results allowed us to validate the parallelization algorithm and to carry out a preliminary analysis of the parallelization benefits in terms of improved energy efficiency and reduced aging speed. Further efforts will be devoted to expanding the battery model to include thermal and aging effects. We finally note that many BMSs embed a protection switch, which can also be used for the parallelization function, and provide a digital communication with the tool. The parallelization algorithm can easily be translated into a relatively simple software routine, which can be executed by the tool controller. Thus, no additional electronic hardware is required to enable battery parallelization in this case.

REFERENCES

- [1] J. V. Barreras, C. Fleischer, A. E. Christensen, M. Swierczynski, E. Schaltz, S. J. Andreasen, and D. U. Sauer, "An Advanced HIL Simulation Battery Model for Battery Management System Testing," *IEEE Trans. Ind. Appl.*, vol. 52, no. 6, pp. 5086–5099, Nov. 2016.
- [2] M. Mergener, "Power Tool Having Multiple Battery Packs," pp. 1–25, 2014.
- [3] J. Shen, S. Dusmez, and A. Khaligh, "Optimization of Sizing and Battery Cycle Life in Battery/Ultracapacitor Hybrid Energy Storage Systems for Electric Vehicle Applications," *IEEE Trans. Ind. Informatics*, vol. 10, no. 4, pp. 2112–2121, Nov. 2014.
- [4] R. Gogoana, M. B. Pinson, M. Z. Bazant, and S. E. Sarma, "Internal resistance matching for parallel-connected lithium-ion cells and impacts on battery pack cycle life," *J. Power Sources*, vol. 252, pp. 8–13, Apr. 2014.
- [5] F. An, J. Huang, C. Wang, Z. Li, J. Zhang, S. Wang, and P. Li, "Cell sorting for parallel lithium-ion battery systems: Evaluation based on an electric circuit model," *J. Energy Storage*, vol. 6, pp. 195–203, 2016.
- [6] F. Baronti, R. Di Rienzo, N. Papazafirooulos, R. Roncella, and R. Saletti, "Investigation of series-parallel connections of multi-module batteries for electrified vehicles," in *2014 IEEE Int. Electr. Veh. Conf.*, 2014, pp. 1–7.
- [7] R. Di Rienzo, F. Baronti, F. Vellucci, F. Cignini, F. Ortenzi, G. Pedè, R. Roncella, and R. Saletti, "Experimental analysis of an electric minibus with small battery and fast charge policy," in *2016 Int. Conf. Electr. Syst. Aircraft, Railw. Sh. Propuls. Road Veh. Int. Transp. Electr. Conf.* IEEE, Nov. 2016, pp. 1–6.
- [8] S. Nejad, D. Gladwin, and D. Stone, "A systematic review of lumped-parameter equivalent circuit models for real-time estimation of lithium-ion battery states," *J. Power Sources*, vol. 316, pp. 183–196, Jun. 2016.
- [9] F. Baronti, G. Fantechi, E. Leonardi, R. Roncella, and R. Saletti, "Enhanced model for Lithium-Polymer cells including temperature effects," in *IECON 2010 - 36th Annu. Conf. IEEE Ind. Electron. Soc.* IEEE, Nov. 2010, pp. 2329–2333.