

Performance analysis of correlation techniques for noise measurements

M. Macucci*, G. Basso*, G. Fiori*, P. Marconcini*, I. A. Maione[†], B. Pellegrini*

*Dipartimento di Ingegneria dell'Informazione, Università di Pisa,
Via G. Caruso 16, 56122 Pisa, Italy
g.basso@iet.unipi.it

[†]Institute for Neutron Physics and Reactor Technology (INR),
Karlsruhe Institute of Technology (KIT),
Campus Nord, Hermann-von-Helmholtz-Platz 1,
76344 Eggenstein-Leopoldshafen, Germany

Abstract—The cross-correlation technique makes it possible to perform noise measurements with a sensitivity that would otherwise be unreachable, well below the noise floor of the amplifiers. Not all noise contributions from the amplifiers can however be eliminated or even just attenuated by cross-correlation: therefore it is important to take into consideration the detailed characteristics of the DUT (Device Under Test) and of the amplifiers when setting up the measurement system. Here we discuss the relative advantages of the different (“series” and “parallel”) configurations coupled with our technique for the accurate evaluation of the transimpedance between the noise source to be measured and the amplifier output. In particular, we show (i) the importance of the comparison between the real and the imaginary part of the cross-spectrum due to the asymmetry of the correlation amplifiers and (ii) how to estimate the maximum number of averages in the cross-spectrum evaluation that leads to an actual advantage from the point of view of the measurement accuracy. Finally we discuss the issue of shielding from external spurious signals, whose relevance is often underestimated.

I. INTRODUCTION

In noise measurements there are often situations in which the noise power spectral density to be measured is very close to, or even lower than the noise level due to the measurement amplifier. To reduce the minimum level of DUT noise that can be measured, correlation techniques have been developed and accurately discussed in the literature [1], [2].

Two main configurations can be used in a two-channel correlation measurement setup: the so-called “series” configuration and the “parallel” one. Each of them has both advantages and shortcomings, and an informed choice must be made, based on the characteristics of the DUT and of the available amplifiers. In the following, we discuss the details of the two approaches in the particular implementation that we have developed, which includes the in-situ measurement of the amplifier transfer function.

II. SERIES CONFIGURATION

In the “series” configuration [Fig. 1 (a)] the DUT is connected in series with the two transimpedance amplifiers, whose output voltages are measured. If a two-channel Dynamic

Signal Analyzer (DSA) is used, the two output voltages are digitized, their Fast Fourier Transform is obtained and the cross-spectrum of the two signals is computed. In this way, by acquiring a large number of time records of the noise signal to be measured and computing the average of the thus obtained cross-spectra, the contribution due to the uncorrelated noise sources of the two amplifiers is virtually averaged out and the noise power spectral density of interest can be evaluated, with a residual error due only to the correlated spurious components.

In order to obtain, from the measurement of the voltage cross-spectrum at the output of the two amplifiers, the noise current power spectral density associated with the device under test, the transimpedance of the two amplifiers has to be known as accurately as possible. This can be achieved with its direct measurement, in the same condition in which the noise measurement is performed, and with the DUT and its bias network (if necessary) in place. To do this, two voltage sources V_s and $-V_s$ (which can be obtained from V_s by means of a unity-gain inverting amplifier) are used: they provide, through the impedances Z_s , a current that is injected into the amplifiers, allowing the measurement of their transimpedance.

In a recent paper [3] we have shown that the equivalent cross-spectrum S_{I12} at the DUT can be expressed as

$$\begin{aligned} S_{I12} &= \frac{S_{12}}{|Z_s|^2 H_1 H_2^*} \\ &= S_{I_d} + K_{I1} S_{I_1} + K_{I2} S_{I_2} \\ &\quad + K_{V1} S_{V_1} + K_{V2} S_{V_2} \end{aligned} \quad (1)$$

where S_{12} is the cross-spectrum at the outputs of the two amplifiers, which is directly measured by means of the DSA, $H_1 = V_{o1}/V_s$ and $H_2 = V_{o2}/V_s$ are the transfer functions, respectively, between the external signal sources and the amplifier outputs, $K_{I1} S_{I_1}$ ($K_{I2} S_{I_2}$) is the contribution to S_{I12} of all noise current sources at the input of amplifier 1 (2), $K_{V1} S_{V_1}$ ($K_{V2} S_{V_2}$) is the contribution to S_{I12} of all noise voltage sources at the input of amplifier 1 (2), and

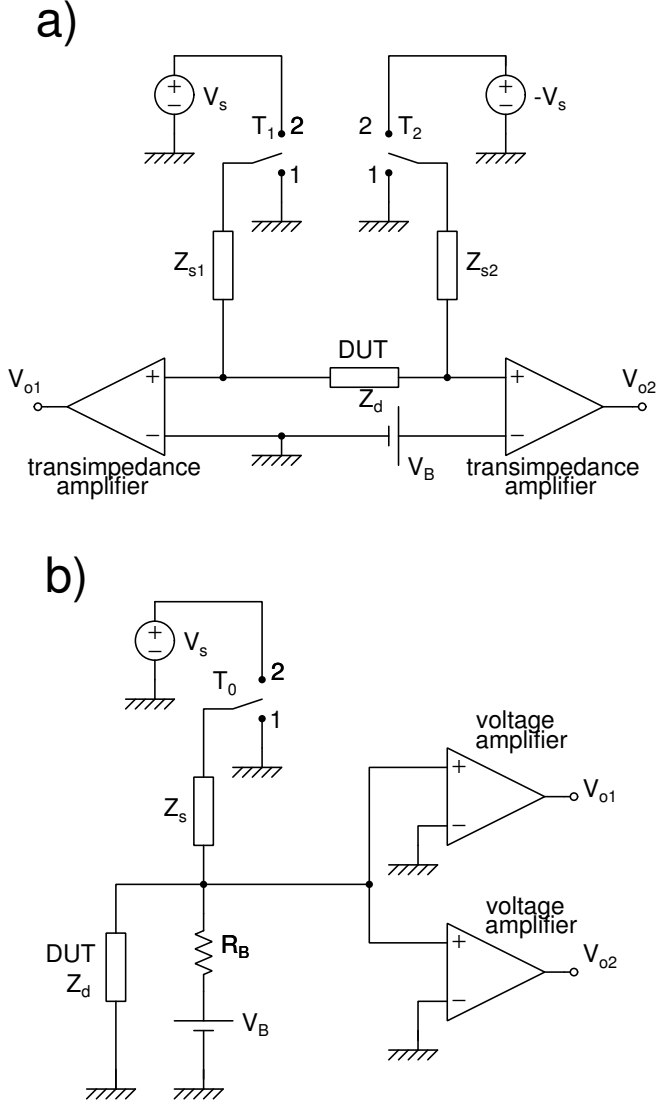

Fig. 1. (a) Series and (b) parallel configurations of the correlation amplifier.

S_{I_d} is the noise current power spectral density due to the DUT, i.e. the quantity of interest in our measurements. In most digital signal analyzers, an internal programmable signal source (V_s) with a white spectrum is available, which allows the direct measurement of H_1 and H_2 . As can be seen from the expressions for the K_{I_i} and K_{V_i} coefficients determined in [3], the K_{I_i} terms are much smaller than unity, while the K_{V_i} are of the order of $1/R_d^2$. Thus the contributions from the current noise sources are strongly suppressed, while those from the voltage noise sources are substantially the same as without cross-correlation.

In order to make Z_s as ideal as possible, we usually implement it with a capacitor C_s , which does not introduce any thermal noise and has a value that is relatively constant with frequency, if we use, for example, a low-loss mica capacitor. Moreover, a large enough value of C_s , although limiting the useful bandwidth, makes it possible to neglect

stray capacitances at the amplifier input. In particular cases, for example when measurements at very low frequency are to be performed, it can be preferable to use a resistor as Z_s , otherwise too large a capacitor (and therefore with nonideal characteristics) would be needed. At low frequency the stray capacitance of the resistor has a negligible effect on the overall transfer function and we only need to keep it at a constant and known temperature, in order to be able to subtract its thermal noise contribution.

The terms $K_{I_1}S_{I_1}$, $K_{I_2}S_{I_2}$, $K_{V_1}S_{V_1}$, and $K_{V_2}S_{V_2}$ in (1) contain also the residual correlated components [3].

The series configuration of two transimpedance amplifiers can almost completely suppress the effect of the current noise sources I_n for DUT resistances higher than the optimum value $R^* = V_n/I_n$ (V_n and I_n being the equivalent noise voltage and current sources, respectively, at the amplifier input, and R^* representing the source resistance at which the amplifier noise figure reaches its minimum).

This configuration is satisfactory if the prevalent contribution is from the input current noise sources of the amplifiers, i.e. for large values of the DUT resistance. In the opposite limit, for low values of the DUT resistance, the main contribution to the output noise comes from the input voltage noise sources, and therefore our main interest is to suppress them, instead of the current sources.

III. PARALLEL CONFIGURATION

In the case of a DUT with a low resistance (or, more in general, with a low impedance modulus) it is possible to exploit the dual configuration with respect to the one discussed so far. In the “parallel configuration” two voltage amplifiers (characterized by an extremely low level of the power spectral density of the equivalent input voltage noise source) are connected in parallel [Fig. 1 (b)] with the DUT. This configuration makes it possible to almost suppress the effects of the noise voltage sources V_n at the input of the amplifiers.

As in the previous case, the current noise power spectral density of the DUT can be obtained from the measurement of the cross-spectrum between the amplifier outputs.

By measuring the transfer functions $H_1 = V_{o1}/V_s$ and $H_2 = V_{o2}/V_s$ between V_s and the amplifier outputs, one can take into account the effects of the DUT impedance and of the bias network (if necessary) on the amplifier gain. Note that $Z_s H_1 (Z_s H_2)$ is the transimpedance of amplifier 1 (2). This approach extends a previously presented method [4] to the case of two amplifiers.

In [3] it was also shown that, in the case of the parallel configuration, the total cross-spectrum can be expressed as

$$S_{I12} = \frac{S_{12}}{|Z_s|^2 H_1 H_2^*} = S_{I_d} + S_I + K'_{V_1} S_{V_1} + K'_{V_2} S_{V_2}, \quad (2)$$

with S_{12} , Z_s , H_1 , H_2 having the same meaning as before, S_I being the power spectral density of the current noise source at the amplifier inputs, and $K'_{V_1} S_{V_1}$ and $K'_{V_2} S_{V_2}$ representing,

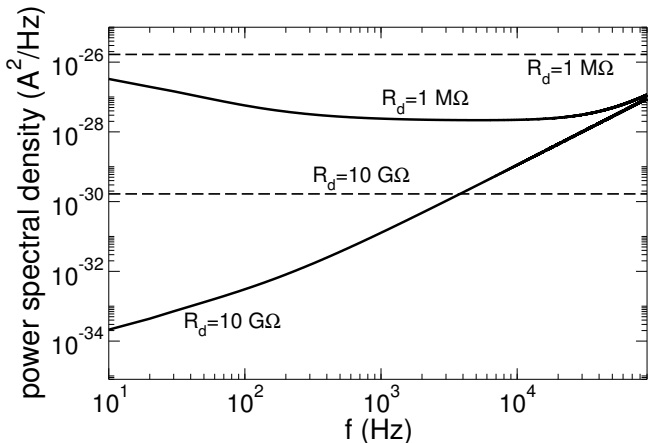

Fig. 2. S_{res} (eq. 3) as a function of frequency (solid lines) associated with the residual noise of the correlated sources, for R_d equal to the low-frequency transimpedance of the amplifier (series configuration). The dashed lines represent the thermal noise.

respectively, the contributions due to the noise voltage sources at the input of amplifiers 1 and 2.

Thus, with the parallel configuration, the contributions from the equivalent input current noise sources are included with a unitary coefficient, while those from the equivalent input voltage noise sources are strongly suppressed, since the K'_{V_i} coefficients are of the order of $(Z_{in}Z_d)^{-1}$, where Z_{in} is the input impedance of the amplifier and Z_d is the DUT impedance (the direct contribution, without cross correlation, of the equivalent noise input voltage source would be of the order of S_V/Z_d^2).

This technique can also be applied using 4 amplifiers [5], with the advantage that the contribution of both the noise and the current input equivalent sources can be canceled, at the price of a more time consuming and more complex measurement procedure.

IV. PERFORMANCE ANALYSIS

Due to the characteristics of the two configurations, and in particular to the significant contribution of the internal noise sources of the amplifiers, for small DUT impedance in the series configuration and for high impedance in the parallel one, the two methods can be considered as complementary, in particular if a wide range of sample impedances has to be investigated.

On the basis of Eqs. (1) and (2), in the case of a perfectly symmetric system, $K_{I_1} = K_{I_2}^*$, $K_{V_2} = K_{V_1}^*$, and $K'_{V_1} = K'_{V_2}$ (as shown in [3]), thus the cross spectrum resulting from the DUT source and from the residual correlated noise components (S_{res}) would be real, because the imaginary part would vanish. In this (ideal) case we would obtain

$$S_{I_{12}} = S_{I_d} + S_{\text{res}} \quad (3)$$

where S_{res} is the contribution to $S_{I_{12}}$ of the residual correlated components. In Figs. 2 we report S_{res} as a function of frequency for the case of a series configuration based on

transimpedance amplifiers each consisting of an operational amplifier with a feedback resistor equal to the one used as a DUT (thermal noise is being measured in this example). The power spectral density of the equivalent input noise current source is 3.6×10^{-31} A²/Hz and that of the equivalent input noise voltage source is 4.9×10^{-17} V²/Hz. If, for example, a precision of 10% is required, the measurement will be possible, with a large enough number of averages, in the frequency intervals for which S_{res} is at least 10 dB below the DUT noise.

Since no real-world correlation amplifier has two identical amplification channels, an imaginary component will always be present in the result of the measurement of the cross-spectrum, even if all the uncorrelated terms (which can be another source of contributions to the imaginary part) have been averaged out. The relative amplitude of the imaginary part with respect to that of the real part can represent an indication of the quality of the measurement, since only undesired components (the residual correlated terms or the uncorrelated terms) can contribute to the imaginary part. In Fig. 3 we report the result of two measurements, one [Fig. 3 (a)] that has been performed in critical conditions, with an input noise power spectral density below the threshold for reliable operation and the other [Fig. 3 (b)] that has yielded a proper estimate of the DUT noise power spectral density. Both the real and imaginary parts are reported, and it is possible to see that, while in Fig. 3 (a) they are of comparable amplitude, in Fig. 3 (b) the imaginary part is at least 15 dB below the real part. In general, the absence or negligibility of the imaginary part does not warrant the quality of the measurement, but its presence is clear evidence of an unreliable result.

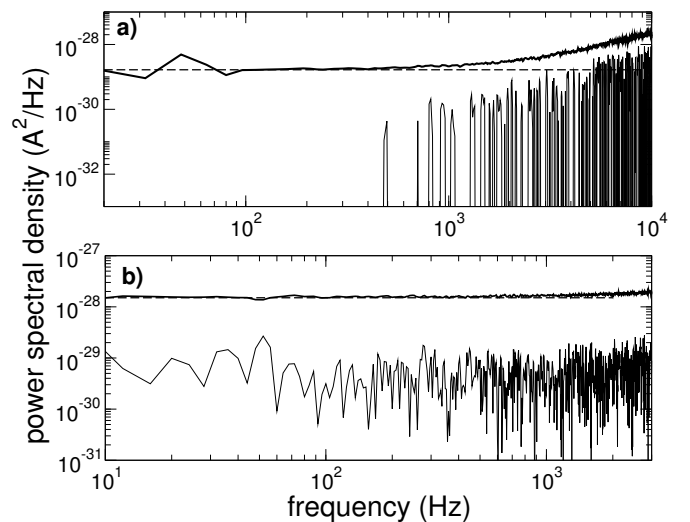

Fig. 3. Real (upper, thick solid line) and imaginary (lower, thin line) part of the noise cross-spectrum measured (a) on a 1 GΩ and (b) on a 100 MΩ DUT. The smaller distance between the two curves in (a), especially at higher frequencies, is an indicator of the poor quality of the measurement. In both cases, the dashed line represents the ideal thermal noise level of the DUT.

As a consequence of the averaging procedure, a reduction

of the magnitude of the uncorrelated component at the output of the amplifier, with respect to the one (S_{single}) that could be achieved with a single time record, is obtained: ideally, averaging over an infinite number of time series would reduce the uncorrelated component to zero [6].

For the series configuration, for example, an estimate S_{single} of the cross spectrum obtained from a single time series reads [3]:

$$S_{\text{single}} \approx 2\sqrt{S_{I_d}}\sqrt{S_I} + S_I + 2\left(\sqrt{S_{I_d}} + \sqrt{S_I}\right) \times \sqrt{S_V}(|Y_p| + |Y_d|) + S_V(|Y_p|^2 + |Y_d|^2), \quad (4)$$

where $S_I = S_{I_1} = S_{I_2}$, $S_V = S_{V_1} = S_{V_2}$, $Y_d = 1/Z_d$ and $Y_p = 1/Z_d + 1/Z_s + 1/Z_k$, Z_k being the feedback impedance connected between the output and the inverting input of an operational amplifier to obtain the transimpedance amplifier. This result is valid in the hypothesis that the input impedances of the transimpedance amplifiers have a modulus much smaller than that of the DUT impedance (thereby minimizing the contribution of each equivalent input current noise source to the output of the amplifier on the opposite side of the DUT).

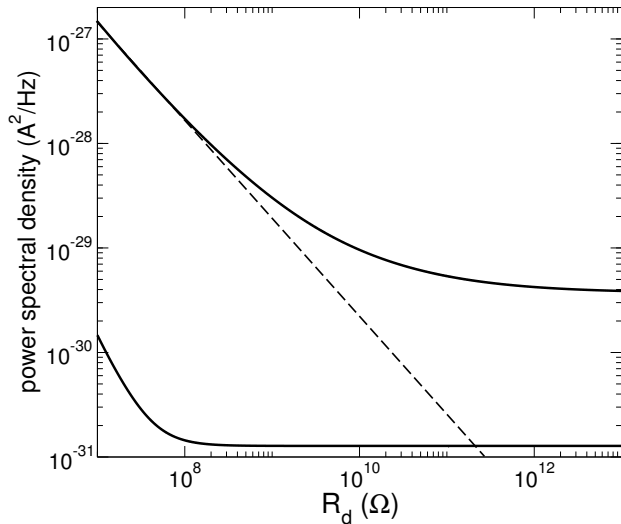

Fig. 4. Plot of S_{res} (lower solid line), of the power spectral density obtained for a single noise time series S_{single} (upper solid line), and thermal noise of R_d (dashed line) as a function of R_d , computed for $f = 1$ kHz and $f R_d = Z_k$ (series configuration). The distance between the curves S_{single} and S_{res} corresponds to the logarithm of $\sqrt{2N'}$, with N' being the number of averages needed to make the standard deviation of the estimate of the uncorrelated noise component in the cross-power spectral density equal to the residual unwanted correlated one.

If N averages on independent time records are performed the standard deviation of the uncorrelated component in such estimate decreases by a factor \sqrt{N} [6], [7], and, if only the real part of the cross-spectrum is considered, $\sqrt{2N}$. When a number of averages N' is performed such that the uncorrelated component equals the residual correlated component, any further averaging could, at most, reduce the overall unwanted contributions by 3 dB, therefore N' can be considered as the maximum number of averages that makes sense to perform from a practical point of view. In Fig. 4 we report the values

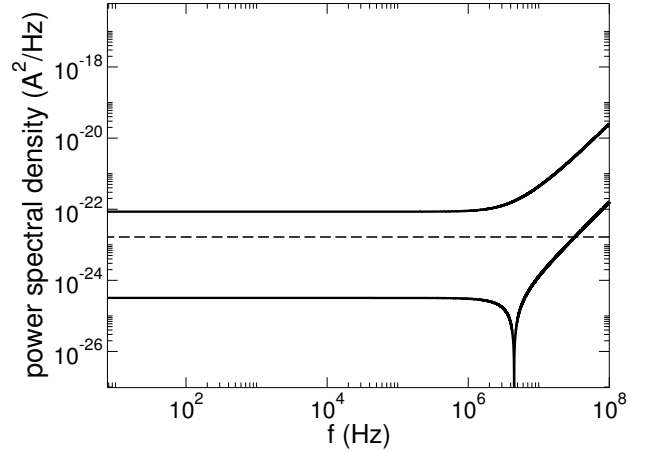

Fig. 5. Plot of S_{single} (upper solid line) and $|S_{\text{res}}|$ (lower solid line) as a function of frequency for $R_d = 1$ k Ω (parallel configuration). The dashed line represents thermal noise.

of S_{single} and S_{res} as a function of the DUT resistance for the series configuration with the same amplifier characteristics as for Fig. 2. Also in this case the feedback resistor is assumed to have the same resistance value as the DUT. Analogous data for the parallel configuration are provided in Fig. 5, for which we have considered voltage amplifiers with a power spectral density of the equivalent input voltage noise source of 9×10^{-18} V²/Hz and a power spectral density of the equivalent input current noise source of 0.16×10^{-24} A²/Hz (these are the values for the OP27 operational amplifier).

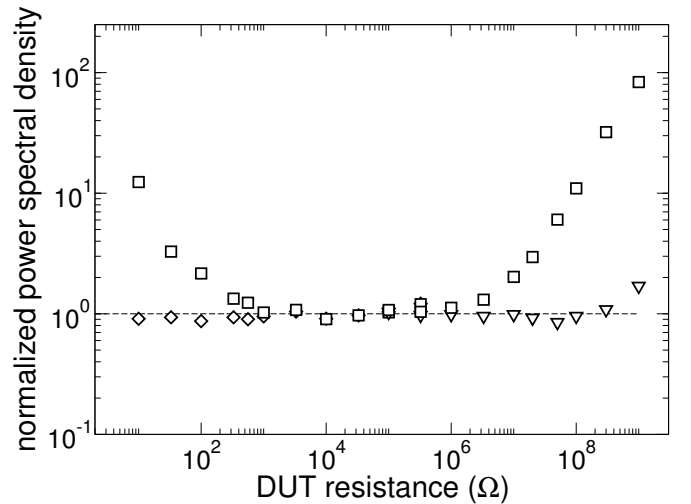

Fig. 6. Normalized noise current power spectral density measured with the correlation amplifier in the parallel (triangles) and the series (diamonds) configuration for a resistance in the range $10\Omega < R_d < 1$ G Ω at $f = 100$ Hz. The squares represent the noise level that would have been obtained if a single voltage ($R_d < 100$ k Ω) or transimpedance ($R_d > 100$ k Ω) amplifier had been used.

With the choice of amplifiers that we have made for the previous figures, we can make a comparison between the

performance of the two configurations and that achievable without correlation. In Fig. 6 we report the result of a thermal noise measurement performed with the parallel (diamonds) and series (triangles) configurations as a function of the DUT resistance. The plotted quantity is normalized with respect to the exact result; the squares correspond to the results that would be obtained with one of the measurement amplifiers, without the cross-correlation technique. Data for the parallel configuration are reported for values of the DUT resistance below 100 k Ω and those for the series configuration for values of the DUT resistance above 100 k Ω .

V. SHIELDING

The cross-correlation method is typically adopted for the precise evaluation of the noise power spectral density of sources characterized by an extremely low noise level. In such situations, shielding becomes essential, in order to prevent electromagnetic coupling to external sources of undesired interferences, in particular those associated with the mains frequency and relative harmonics. We have developed a particularly accurate approach to shielding, trying to avoid any ground loop (which could couple with stray magnetic field from transformers) and using a double enclosure for the sample and the stages handling low-level signals. A graphic

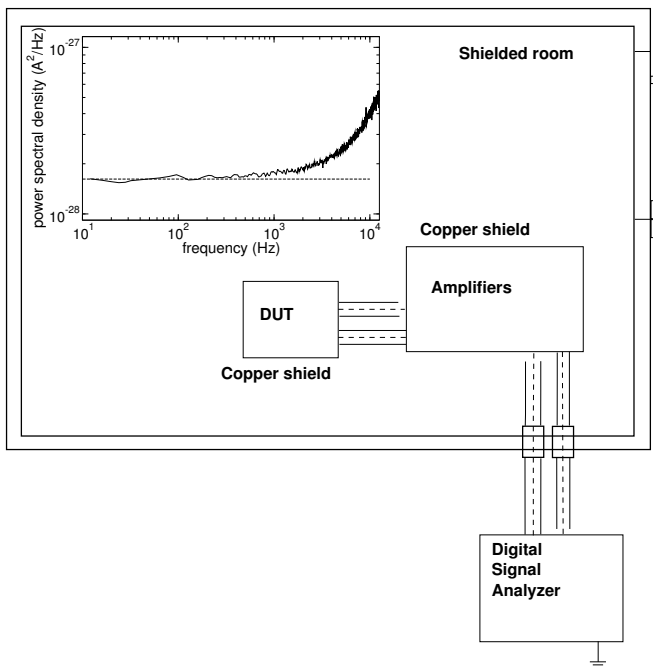

Fig. 7. Sketch of the shielding adopted for the measurement system.

representation of our setup from the point of view of shielding and grounding is reported in Fig. 7: the amplifiers and the batteries powering them are included in a copper box that is connected with two coaxial cables to another copper box containing the DUT (if the DUT does not require additional batteries for biasing, as in the case of resistors, cooling or heating, it can be placed in the same box as the amplifiers). Both the DUT and the amplifier boxes are kept in a shielded

room and the output signals of the amplifiers are routed to the external DSA by means of coaxial feedthroughs crossing the wall of the shielded room. Notice that ground loops are avoided using, wherever needed, BNC connectors with insulated ground.

This setup has allowed us to achieve measurements of very low noise levels with no trace of external interferences, as shown in the inset of Fig. 7, where we report the power spectral density as a function of frequency for the thermal noise of a 100 M Ω resistor. There is no observable spurious component at the mains frequency or its harmonics or from the power supply of the DSA. In the literature, peaks at the mains frequency and its harmonics are often present in low-level measurements (see, for example Ref. [8]), and are removed by means of off-line digital filtering. Such filtering removes the undesired components, but the dynamic range of the DSA is not restored to the one that could be achieved in the absence of the undesired components, which is particularly limiting when the interfering spectral lines have a large amplitude, so that a significantly reduced number of bits is used for the analog to digital conversion of the useful quantity.

VI. CONCLUSION

Series and parallel configurations for noise measurements with the cross-correlation technique have been compared, pointing out the relative advantages and the improvement resulting from the in-situ evaluation of the amplifier transimpedance. Furthermore, we have suggested the importance of monitoring the relative amplitudes of the real and imaginary parts of the cross-spectrum, because the presence of a significant imaginary part is evidence of an unreliable result. We have also discussed the maximum achievable sensitivity, as a result of the presence of spurious correlated contributions, and the number of averages in the estimate of the cross spectrum beyond which a further improvement of at most 3 dB can be achieved.

We have applied the techniques discussed in this paper to measurements in harsh conditions, achieving interesting results. For example, we have performed the noise characterization of p - n junctions at current levels down to 10 pA [9], and the measurement of shot noise in double barrier resonant tunnel devices operating at current levels below 1 pA [10].

REFERENCES

- [1] M. Sampietro, L. Fasoli, G. Ferrari, "Spectrum Analyzer with Noise Reduction by Cross-correlation Technique on Two Channels," *Rev. Sci. Instrum.*, vol. 70, 2520, 1999.
- [2] G. Ferrari, M. Sampietro, "Correlation spectrum analyzer for direct measurement of devices current noise," *Rev. Sci. Instrum.*, vol. 73, 2717, 2002.
- [3] B. Pellegrini, G. Basso, G. Fiori, M. Macucci, A. Maione, P. Marconcini, "Improvement of the accuracy of noise measurements by the two-amplifier correlation method," *Rev. Sci. Instrum.*, vol. 84, 104702, 2013.
- [4] M. Macucci, B. Pellegrini, "Very sensitive measurement method of electron devices current noise," *IEEE Trans. Instrum. Meas.*, vol. 40, p. 7, 1991.
- [5] F. Crupi, G. Giusi, C. Ciofi, C. Pace, "Enhanced sensitivity cross-correlation method for voltage noise measurements," *IEEE Trans. Instrum. Meas.*, vol. 55, p. 143, 2006.

- [6] G. M. Jenkins, D.G. Watts, *Spectral Analysis and Its Applications*, Holden-Day, Oakland, CA,(1968).
- [7] P. D. Welch, "The use of Fast Fourier Transform for the Estimation of Power Spectra: A Method Based on Time Averaging over Short, Modified Periodograms," *IEEE Trans. Audio Electroacoust.*, vol. AU-15, p. 70, 1967.
- [8] V. K. Sangwan, H. N. Arnold, D. Jariwala, T. J. Marks, L. J. Lauhon, and M. C. Hersam, "Low-frequency electronic noise in single-layer MoS₂ transistors," *Nano Letters* vol. 13, p. 4351, 2013.
- [9] I.A. Maione, B. Pellegrini, G. Fiori, M. Macucci, L. Guidi, G. Basso, "Shot noise suppression in pn junctions due to carrier generation-recombination," *Phys. Rev. B*, vol. 83, p. 155309, 2011.
- [10] I. A. Maione, M. Macucci, G. Iannaccone, G. Basso, B. Pellegrini, M. Lazzarino, L. Sorba, F. Beltram, "Probing Pauli blocking with shot noise in resonant tunneling diodes: Experiment and theory," *Phys. Rev. B*, vol. 75, p. 125327, 2007.