



SCIENCE, TECHNOLOGY AND SYSTEMS ENGINEERING EDUCATIONAL ACTIVITIES WITH STRATOSPHERIC BALLOONS

Salvo Marcuccio, Matteo Gemignani, Giuseppe Cataldi

Dept. of Civil and Industrial Engineering, Università di Pisa, Italy

Abstract

The Space Systems Laboratory of the University of Pisa started in 2021 a student-oriented high altitude ballooning programme intended to provide an opportunity for hands-on experience in support of scientific and technical courses. Following a call for proposal open to all students across all study areas, three experiments were selected featuring multi-disciplinary teams. The programme provides mentoring on scientific, technical and management issues, financial support and assistance with integration and launch on a sounding balloon platform. The goal is to fly the experiments in the stratosphere, retrieve them after landing and process the results; by doing so, the students experience all phases of a scientific mission project, from conceptual design to realization, operations and post-flight analysis. This paper summarizes the features of the programme's first edition.

Keywords: high altitude ballooning, stratospheric platform, student experiment, sounding balloon

1. Introduction and background

High altitude ballooning is recognized as an inexpensive, yet very effective way of bringing small payloads to a region of the Earth atmosphere where ambient conditions are very close, for many aspects, to those of space. Reaching an altitude of 25 to 40 km during a 2 - 3 hour mission, high altitude balloons (HAB) experience a range of different environmental parameters, such as very low pressure (down to the mbar range) and extreme cold (- 70 °C), together with insolation and ionizing radiation conditions almost identical to those prevailing in LEO. Reaching such "near-space" region is readily feasible for student teams using simple hardware (latex balloons filled with helium) that can be procured at low cost. Figure 1 shows the phases of a typical HAB mission

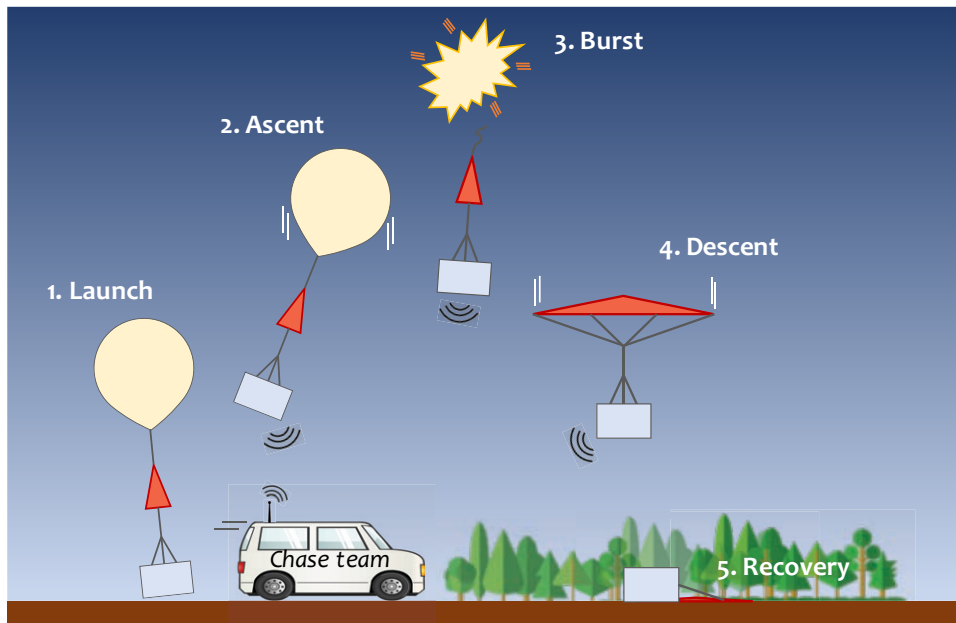

Figure 1 – Phases of a typical HAB mission.

The effectiveness of ballooning for STEM (Science, Technology, Engineering, and Mathematics) educational purposes in middle and high school is widely recognized [1]. At university level, ballooning can be a very powerful tool to perform valuable research [2]. However, the value of a HAB flight project goes beyond pure scientific instruction. When engaging in a HAB project, university students have the opportunity to experience, hands-on and in a fully immersive way, all the aspects of a flight project. Along with the issues involved in designing, instrumenting, building, testing, de-bugging and flying a scientific or technological experiment, the student teams are confronted with the harsh realities of working in a team, under schedule pressure, with budgeted resources. Structured project management is readily acknowledged as a necessity and is quickly learned and willingly applied [3].

Student-dedicated stratospheric flight programs have been active for decades in many countries around the world at universities that use them as teaching aids for students in science and technology disciplines, from engineering to physics, astronomy, and biology. As examples (among dozens of similar international initiatives), several U.S. universities [4] and several Canadian universities [5] maintain such programs. The experiments range from the detection of cosmic rays, to the physics of the upper atmosphere (turbulence, chemical composition), to the observation of the earth in the visible or thermal infrared, to the exposure of biological samples to the radiative environment, to the testing of technologies for telecommunications, remote sensing, sensor technology for satellites, etc. The extensive literature available (e.g., [6, 7]) illustrates the great potential of stratospheric flight experiments in teaching science disciplines and the great favor they meet with students when offered at the university level.

2. The student ballooning programme at UniPi

Since 2018, researchers at the Space Systems Laboratory of the University of Pisa [8] have been carrying out sounding balloon flights at altitudes ranging from 19 to 38 km (Figure 2). So far, 12 flights have been performed for engineering research purposes [9,10] with various technology experiments (telecommunications for Internet-of-Things, receiving AIS signals for maritime detection, solar cells, etc.). In most cases, the experiments were designed, prepared and carried out with active participation of graduate aerospace engineering students as a part of their final projects (Figure 3).



Figure 2 – Coast of Tuscany from about 30 km altitude as pictured by UniPi 01.



Figure 3 – SSL staff and students preparing for launch of UniPi 03.

Leveraging on such experience, the Space Systems Laboratory started a student ballooning programme in 2021. The programme, internally funded by the University of Pisa, provides guidance, mentoring, financial and logistic support to interdisciplinary teams of undergraduate and graduate students willing to undertake the process leading to flight of a small scientific payload in the stratosphere. Such issues as the procurement and management of the flight platforms (balloons, helium, parachute, tracking and telemetry, etc.), the necessary authorization by the flight

control authorities, insurance, and support to operations are provided by the programme. Experiment proposals are evaluated on a competitive basis after a call for proposals open to all the students across any disciplinary areas in the University.

The objectives of the activity are to allow students to experience first hand:

- the conception, realization, testing and management of a scientific experiment in a near-space environment;
- the design and implementation of a complex system within predefined technical and economic constraints;
- the methods of group work aimed at the practical implementation of a scientific experiment, from conception to the presentation of results.

The added value at educational level can be summarized in the following points:

- "hands-on" experience on flight hardware, in the laboratory and during the launch campaign;
- acquisition/improvement of direct knowledge on embedded control systems (Arduino, Raspberry and similar platforms); programming in Python, C++, etc.;
- direct experience in the planning and execution of a scientific project.

In spring 2021, the first batch of proposals was received. After evaluation by the programme committee, the following proposals were selected:

- 1) measurement of cosmic rays flux and neutron flux as a function of altitude;
- 2) investigation of the effects of exposure of selected micro-organisms and other biological material to stratospheric UV radiation as a Mars surface analogue;
- 3) recording of the solar spectrum as a function of altitude.

The experiments were proposed and designed by mixed teams of students from different disciplines, ranging from biology and neurosciences, to physics, to mechanical and aeronautical engineering. The interdisciplinary nature of the teams is one of the most valuable aspects of the programme, allowing the participants to experience early in their student life the joys and sorrows of teamwork, having to establish effective communication and decision-making mechanisms to collaborate among specialists of different sectors.

3. Experiments selected

3.1 Miracle - Cosmic rays

The Miracle project is about measuring the cosmic ray flux and separation of the charged and neutral components. Cosmic rays (CR), elementary particles and atoms that constantly hit the upper parts of the atmosphere, are usually classified into two categories: primary CR, i.e. those particles coming from outer space, and secondary CR, which are generated by the interactions of the primaries with the atmosphere atoms. In particular, the experiment aims to measure the vertical and horizontal flux of the cosmic rays, which depends on the local density of the atmospheric air and therefore on the balloon altitude. To this end, three scintillators are placed perpendicularly to each other, so to catch the vectorial components of the cosmic ray flux.

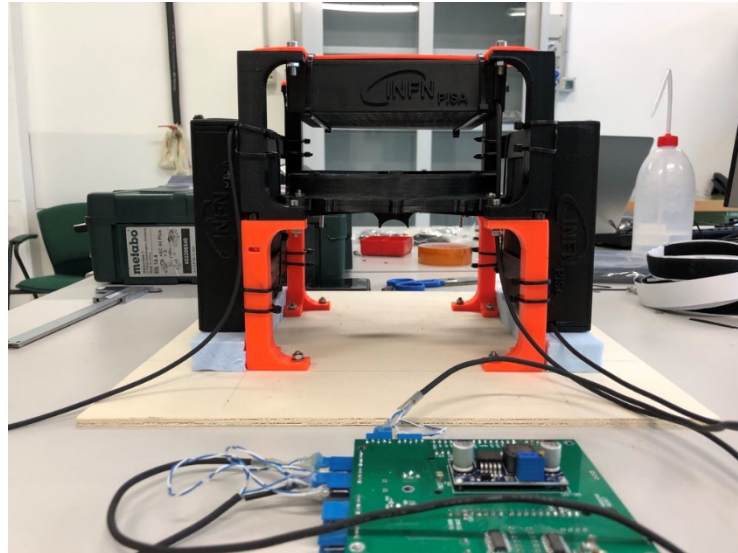

Figure 4 – The payload assembly that will fly on the sounding balloon.

The payload (Figure 4) will also host a sensor that will detect thermal neutrons during the ascent, produced by the interactions between cosmic rays and oxygen and nitrogen atoms. Finally, the Miracle experiment has also the ambitious objective to characterize in the stratosphere the performance of a Micromegas gas-based detector [11], specially built for this occasion at the CERN laboratory in Geneva (Figure 5) and provided through the Pisa branch of the National Institute of Nuclear Physics (INFN).



Figure 5 – Integration of the Micromegas at the INFN (Istituto Nazionale di Fisica Nucleare) laboratory in Pisa

3.2 UV Mars - Biological samples exposed to UV

The UV Mars project has the ambitious goal of sending various types of microorganisms (Figure 6) into the stratosphere to expose them to ultra-violet (UV) radiation. Recent studies have shown how UV irradiation in the upper atmosphere of the Earth can be correlated to the irradiation conditions at the surface of the planet Mars [12]. UV radiation is also to interact with biological material

inducing damage of varying degrees in the different cellular districts. The harmful biological effects of UV are almost completely attributable to photochemical reactions, in which the energy carried by the radiation is able to catalyse a reaction chemistry that could not have occurred under other conditions. For this reason, the UV rays represent a powerful factor capable of altering genomic stability and inducing formation of toxic photoproducts. By exposing biological samples to the stratospheric, unfiltered UV radiation, it is possible to get reliable indications of what the effect would be on the surface of the red planet.

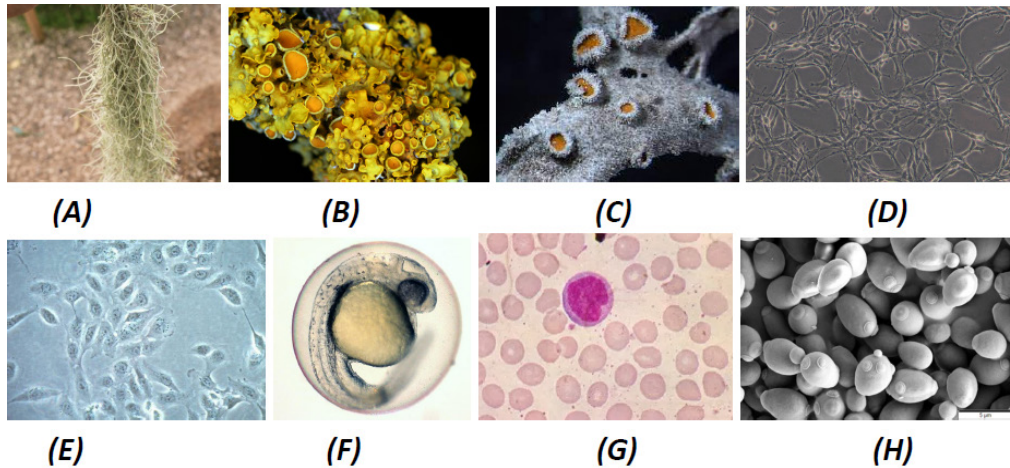

Figure 6 – (A) *Tillandsia Usneoides*, (B) *Xanthoria Parietina*, (C) *Seirophora Villosa*, (D) C6 cells, (E) INS-1 cells, (F) ZebraFish embryos, (G) human peripheral blood lymphocytes, *Saccharomyces Cerevisiae*

For this particular payload, the challenge was to build a sealed chamber (Figure 7), transparent to UV radiation, able to maintain temperature and pressure within the optimal ranges for the survival of the biological species. It will also host a whole set of sensors to measure the variation of the incoming UV radiation while ascending through the atmosphere in order to be able to correlate in postprocessing these measurements to the damage induced to the microorganisms.

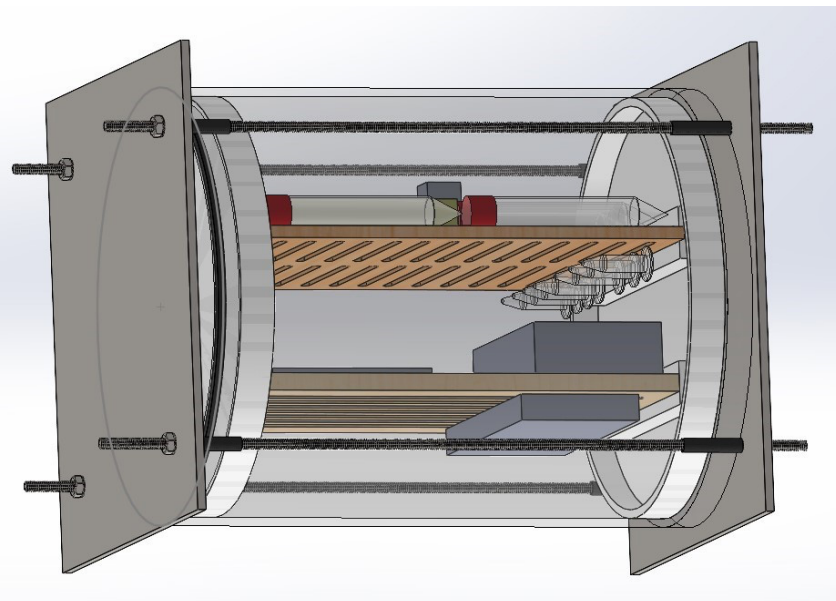

Figure 7 – CAD drawing of the UV Mars payload inside the sealed container

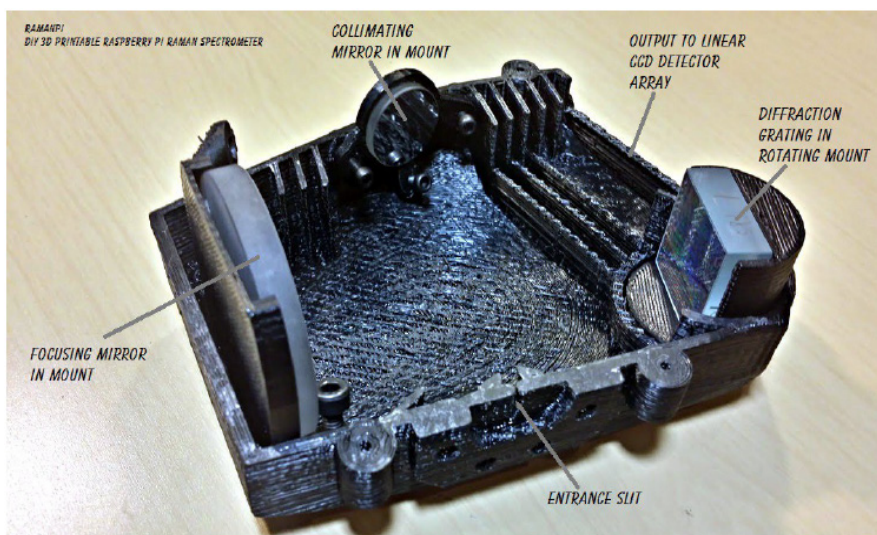

Figure 10 - Assembly of the spectroscopy.

4. Conclusions

As of writing, the experiments have almost completed final assembly and functional testing and each of them is going to be integrated with its own balloon platform. All three launches will take place by early spring 2022, with the actual timing depending on weather conditions and stratospheric wind patterns. A few general considerations on the outcome of this education experience can be anticipated:

- the opportunity to work on a near-space mission from start to end has been very positively received. The students have selected ambitious scientific goals and formed interdisciplinary teams, acting autonomously and with dedication, well beyond expectations. The attractiveness of HAB activities for young people and the strong educational potential of the programme have been confirmed;
- along with the scientific and technical aspects of the project, the students have experienced the need to establish and maintain a few formal procedures to keep work on track and proceed smoothly. In particular, basic project management tools such as scheduling charts, minimal interface description documents and formal meeting minutes have been used with some success;
- the three experiments selected, scientifically sound and stimulating as they are, have proven to be quite challenging for both the students and the supporting faculty. All of them required several design iterations before reaching flight readiness. To the end of the educational experience, simpler experimental goals may prove perfectly adequate and equally rewarding. For future editions of the programme, we'll privilege more basic experiments aimed at selected educational topics, while more scientifically ambitious projects are best carried out as graduate level end-of-study thesis works.

In conclusion, the first edition of the ballooning programme at UniPi has fully met the expectations so far. A second edition has been approved for funding by the academic administration and will start in early 2022. We look forward to making near-space student missions a regular feature of the scientific education at our University and to establish collaborations with other higher education institutions to foster hands-on scientific learning through high-altitude ballooning.

5. Acknowledgments

The authors wish to thank Prof. Gianluca Lamanna of the Department of Physics of the University of Pisa for his creative contribution and substantial support.

6. Contact Author Email Address

Contact author: salvo.marcuccio@unipi.it

7. Copyright Statement

The authors confirm that they, and/or their company or organization, hold copyright on all of the original material included in this paper. The authors also confirm that they have obtained permission, from the copyright holder of any third party material included in this paper, to publish it as part of their paper. The authors confirm that they give permission, or have obtained permission from the copyright holder of this paper, for the publication and distribution of this paper as part of the AEC proceedings or as individual off-prints from the proceedings.

References

- [1] Cheng, S. , Gerhard, D. , Gendron, F. and Ziffle, V. Incorporation of High-Altitude Balloon Experiment in High School Science Classrooms. *Creative Education*, Vol. 10, No. 2, pp 262-272, 2019. doi: 10.4236/ce.2019.102021
- [2] Larson, S., Armstrong, J., Hiscock, W. The First Frontier: High Altitude Ballooning as a Platform for Student Research Experiences in Science and Engineering. *Am. J. Phys.*, Vol. 77, No. 6, pp 489-497, 2009. doi: 10.1119/1.3097775
- [3] Golkar, A. Experiential Systems Engineering Education Concept Using Stratospheric Balloon Missions, *IEEE Systems J.*, Vol. 14, No. 2, pp. 1558-1567, 2020. doi: 10.1109/JSYST.2019.2917823
- [4] <https://www.stratoballooning.org> - Accessed October 22, 2021
- [5] <https://seds.ca/projects/can-sbx/> - Accessed October 22, 2021
- [6] <https://www.iastatedigitalpress.com/ahac/>
- [7] <https://atpi.eventsair.com/QuickEventWebsitePortal/pac-symposium-2021/home1/ExtraContent/ContentPage?page=6>
- [8] <http://spacelab.unipi.it> - Accessed October 22, 2021
- [9] Gemignani, M., Marcuccio, S., “Dynamic Characterization of a High-Altitude Balloon during a Flight Campaign for the Detection of ISM Radio Background in the Stratosphere”, *Aerospace* 2021, 8, 21. doi: 10.3390/aerospace8010021
- [10] Marcuccio, S., Cataldi, G., Gemignani, M., “New Low-Cost Stratospheric Balloon Flight Opportunities with Pisa University’s MicroHAPS Platform”, *Proc. 26th AIDAA Congress, Pisa, Italy, Persiani, 2021*
- [11] Charpak, G., Derré, J., Giomataris, Y., Rebourgeard, Ph., “Micromegas, a multipurpose gaseous detector”, *Nuclear Instruments and Methods in Physics Research, A* 478, 2002, pp. 26-36. doi: 10.1016/S0168-9002(01)01713-2
- [12] Khodadad, C. L., Wong, G. M., James, L. M., Thakrar, P. J., Lane, M. A., Catechis, J. A., & Smith, D. J., “Stratosphere Conditions Inactivate Bacterial Endospores from a Mars Spacecraft Assembly Facility”, *Astrobiology*, 17(4), 2017, pp. 337–350. doi: 10.1089/ast.2016.1549